

CMT SHEET NAME	REF AREA
<i>/sys/cmt_if/prod_test_pattern</i>	<i>2060-2069</i>
<i>/sys/cmt_if/battery_conn</i>	<i>2070-2099</i>
<i>/sys/cmt_if/audio</i>	<i>2000-2029</i>
<i>/sys/cmt_if/audio</i>	<i>2100-2199</i>
<i>/sys/cmt_if/itu</i>	<i>2400-2499</i>
<i>/sys/cmt_if/camera</i>	<i>2500-2599</i>
<i>/sys/cmt_if/sim</i>	<i>2700-2799</i>
<i>/sys/cmt_if/emu_rap</i>	<i>3100-3120</i>
<i>/sys/cmt_if/wing</i>	<i>4000-4099</i>
<i>/sys/cmt_if/lid</i>	<i>3800-3899</i>
<i>/sys/cmt_if/bt</i>	<i>6000-6099</i>
<i>/sys/cmt_if/wlan</i>	<i>6300-6510</i>
<i>/sys/cmt_if/conn/charger-USB</i>	<i>2030-2039</i>

CMT SHEET NAME	REF AREA
<i>/sys/cmt_engine/power/vilma</i>	<i>2200-2299</i>
<i>/sys/cmt_engine/power/betty</i>	<i>2300-2389</i>
<i>/sys/cmt_engine/power/coreps</i>	<i>2390-2399</i>
<i>/sys/cmt_engine/digi/rapido</i>	<i>2800-2849</i>
<i>/sys/cmt_engine/digi/geniomux</i>	<i>2850-2899</i>
<i>/sys/cmt_engine/digi/mem_cmt/combo</i>	<i>3000-3099</i>
<i>/sys/cmt_engine/digi/mem_cmt/sd_card</i>	<i>3200-3299</i>

RF SHEET NAME	REF AREA
<i>/RF</i>	<i>7500-7599</i>
<i>/MUTANT</i>	<i>8000-8010</i>

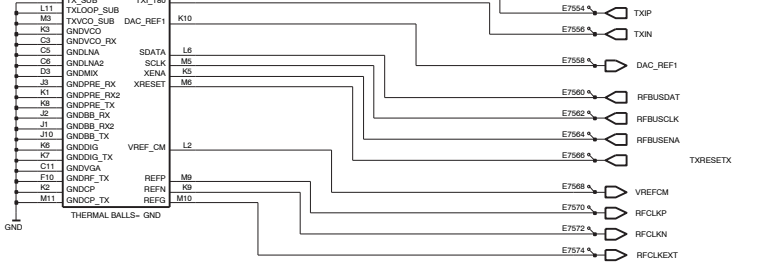

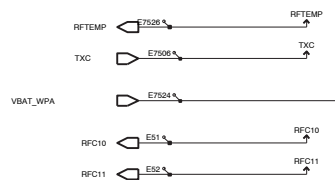
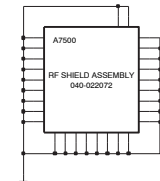
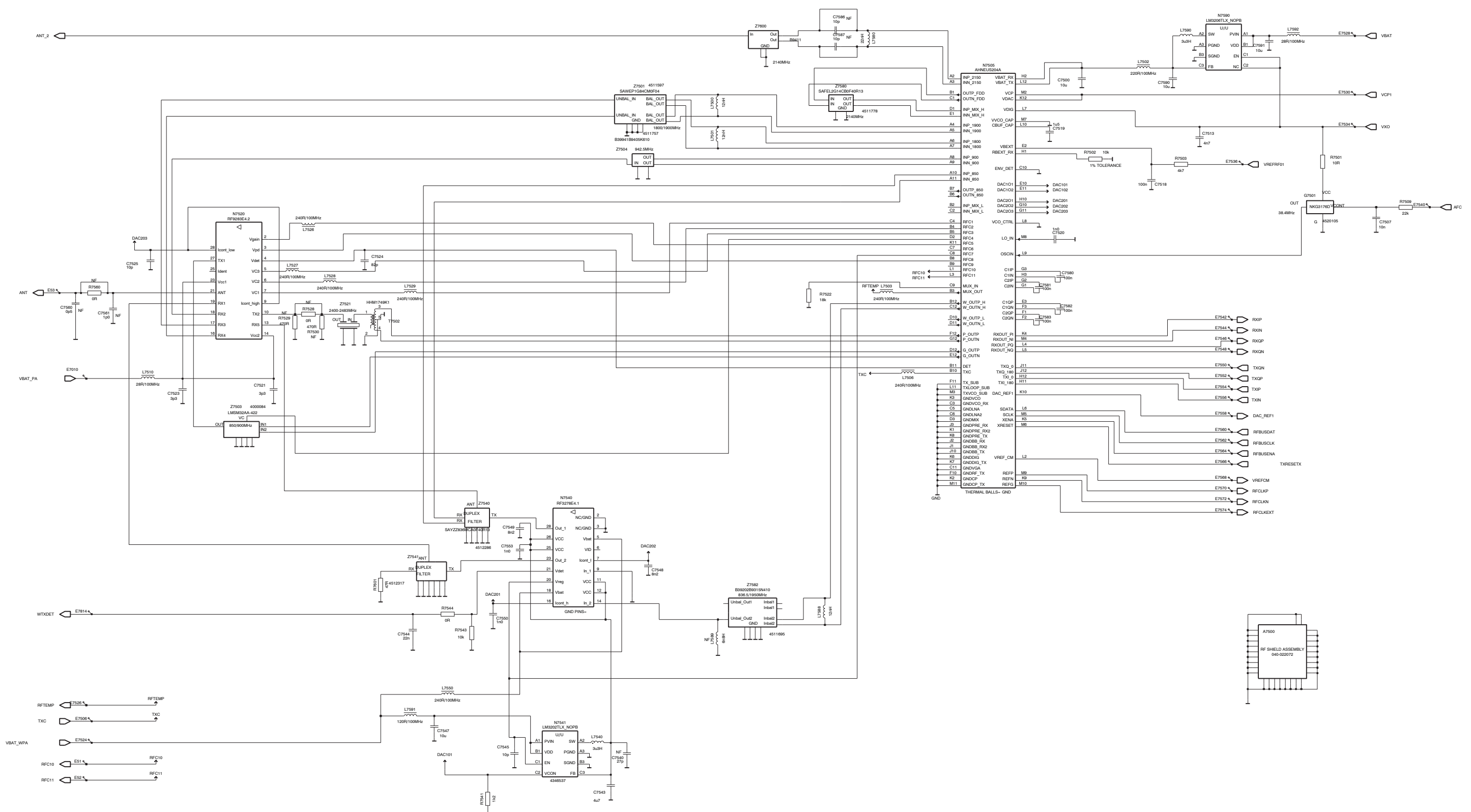
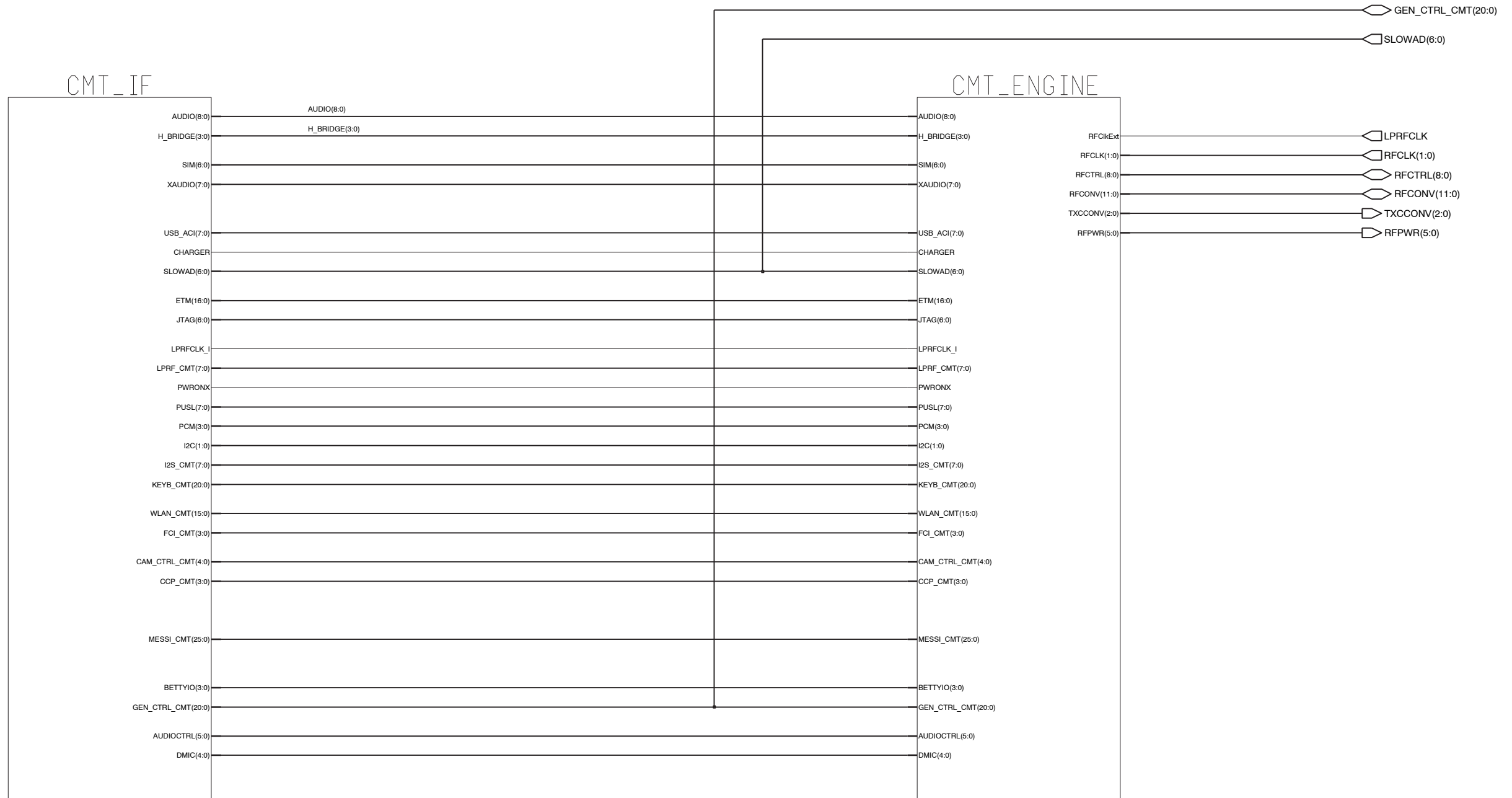

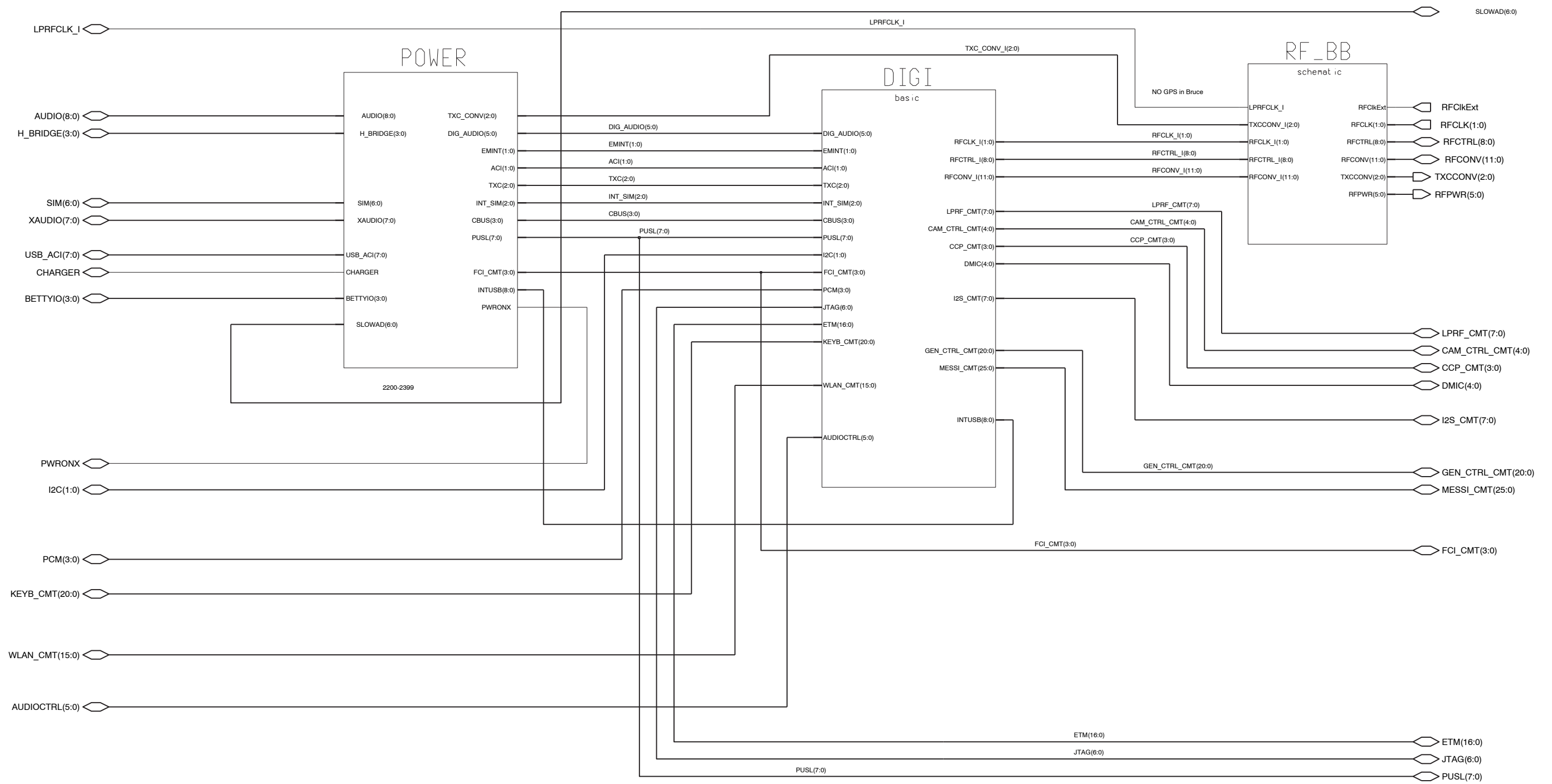

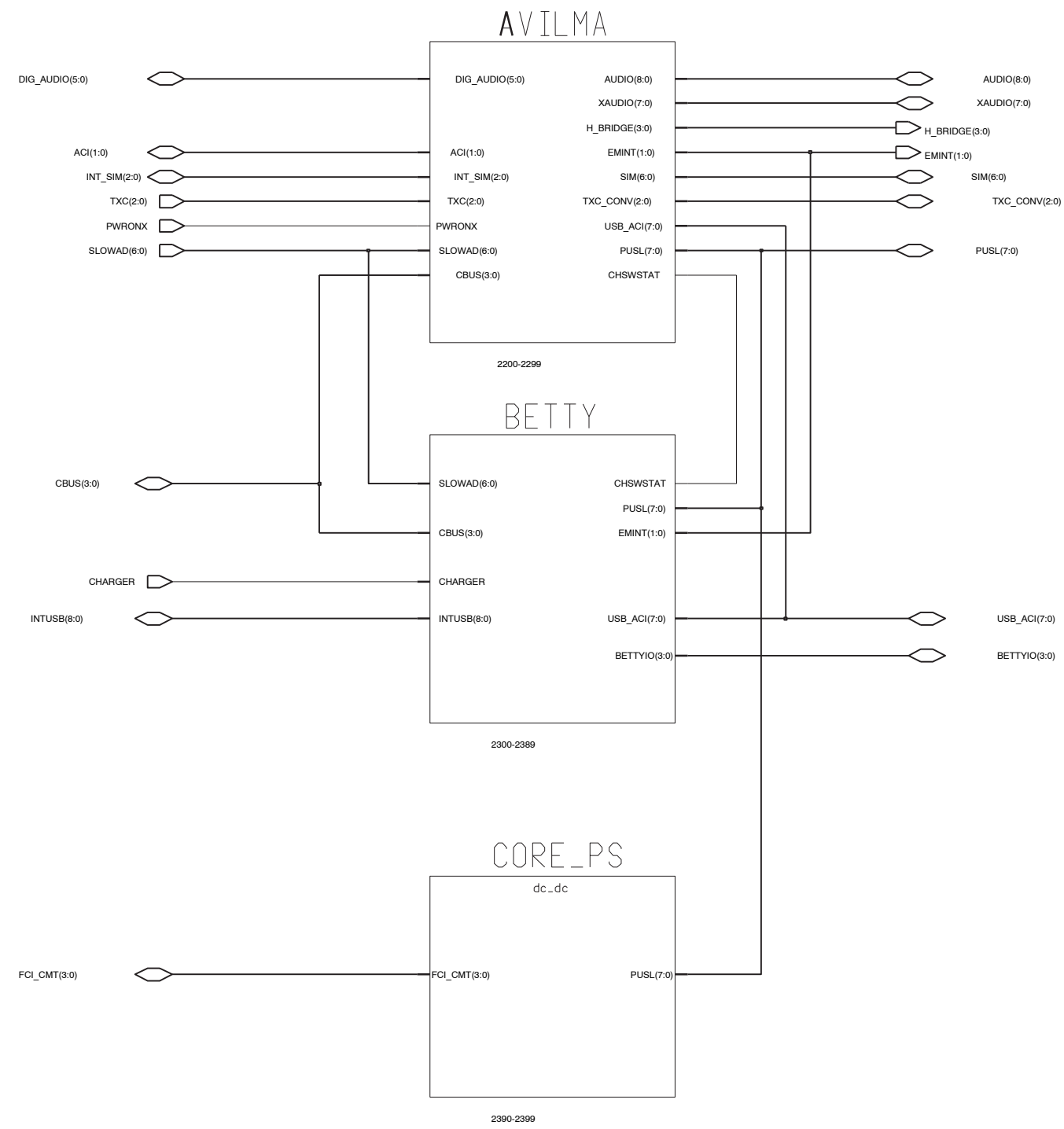

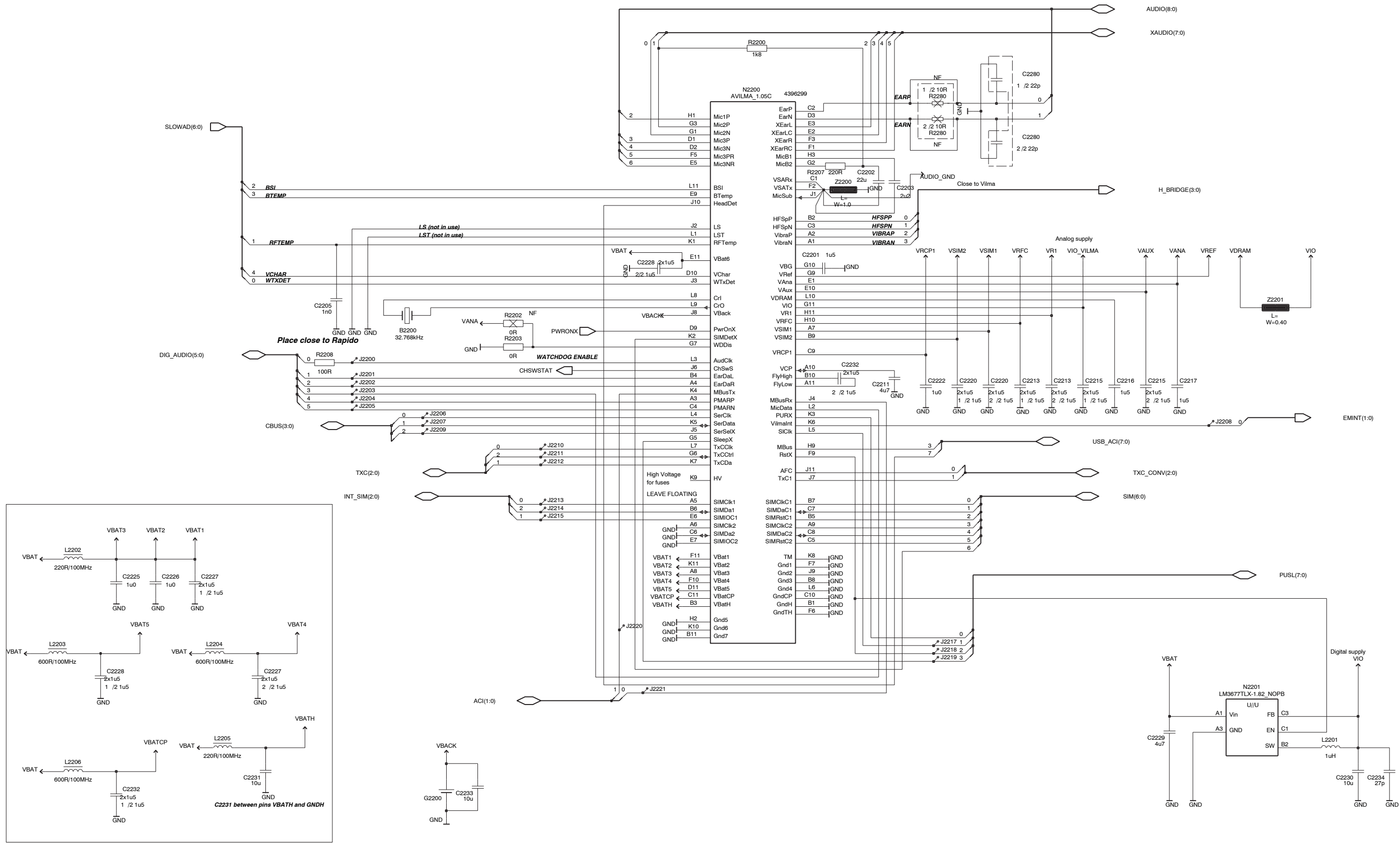

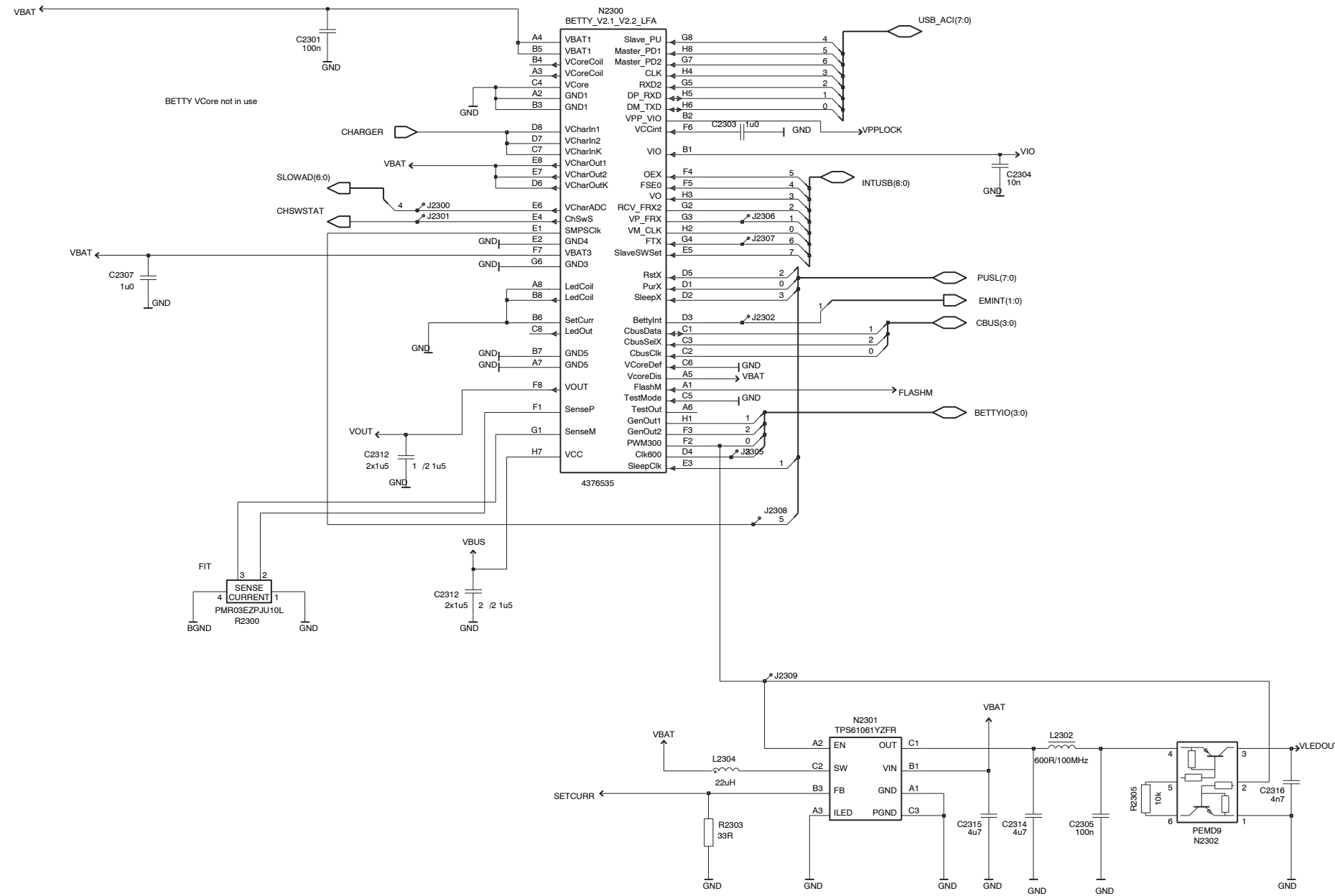

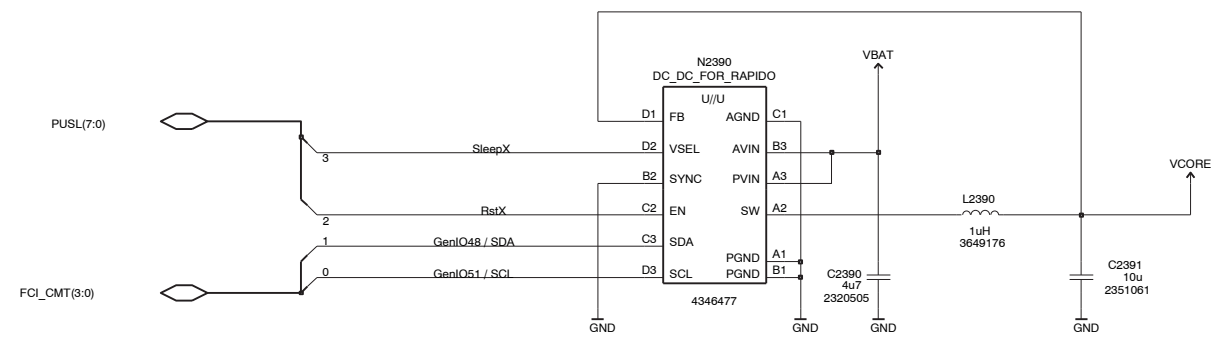

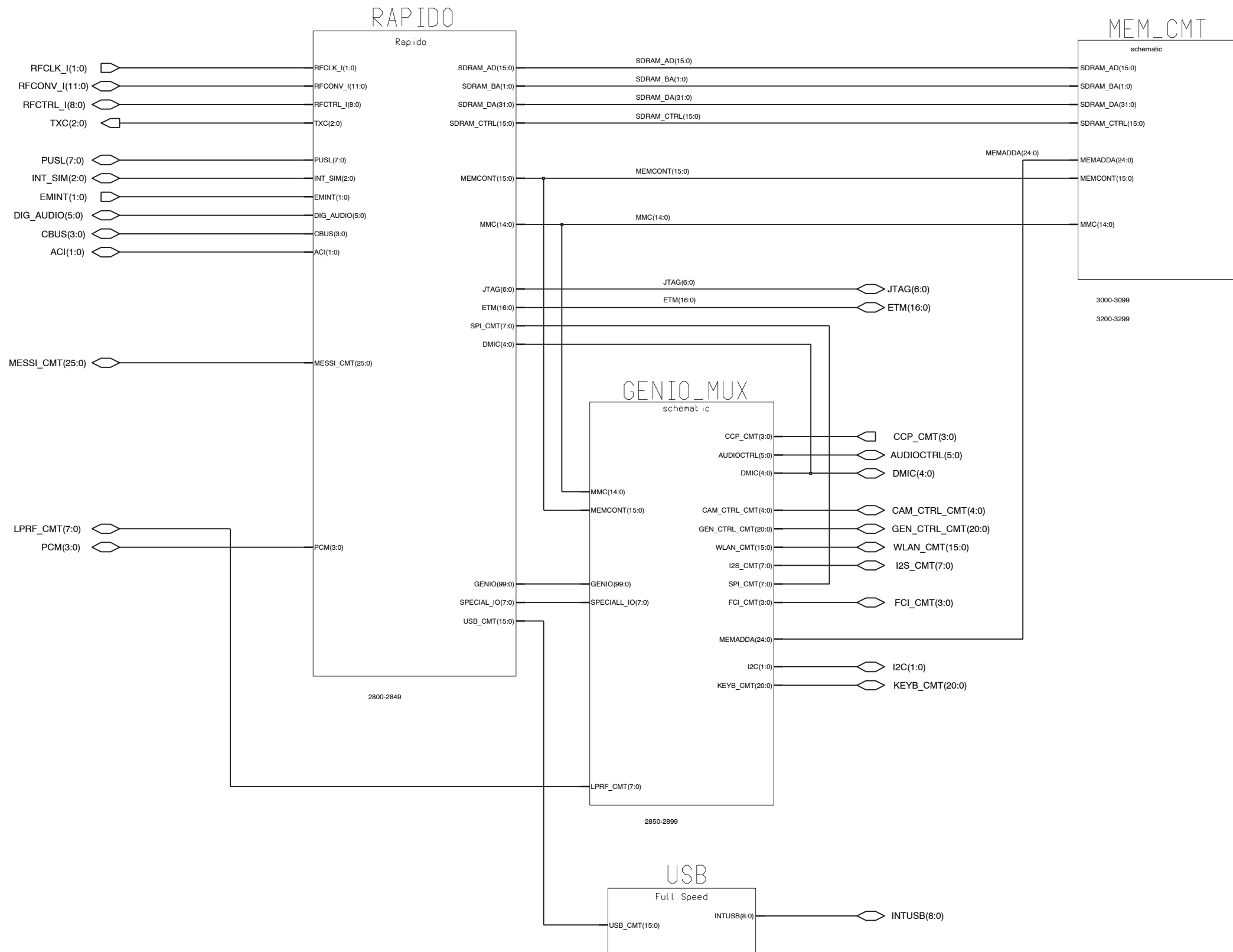

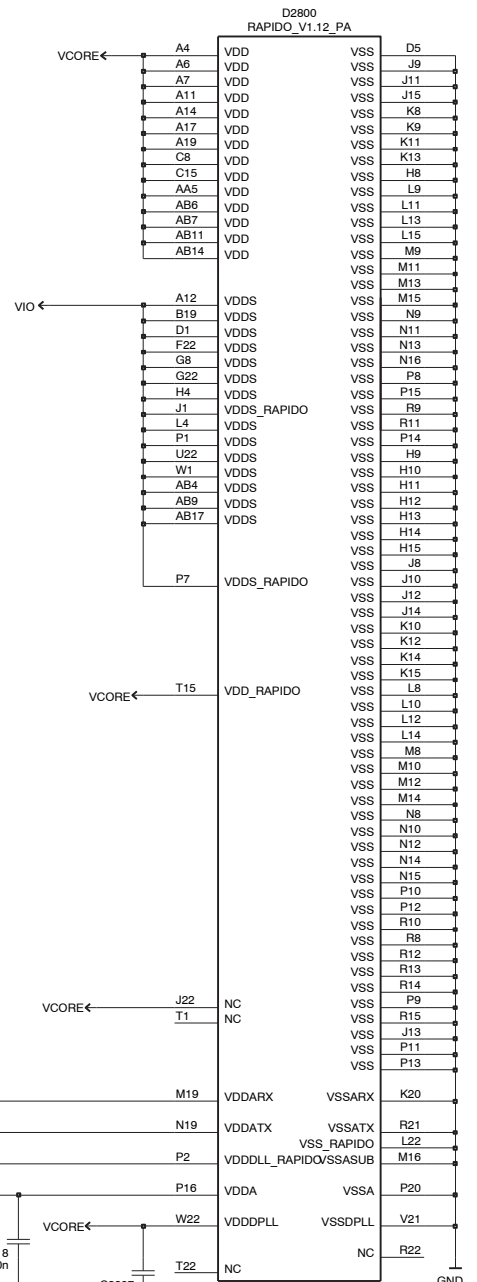
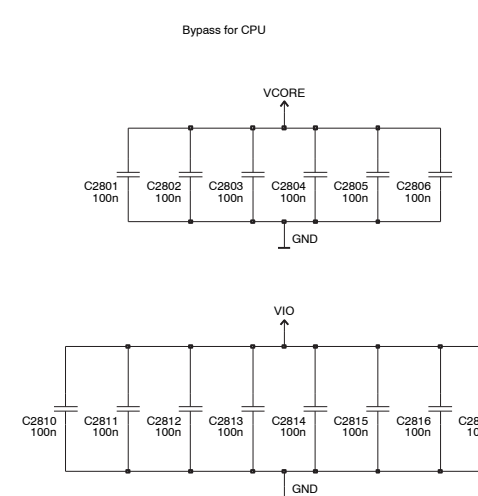
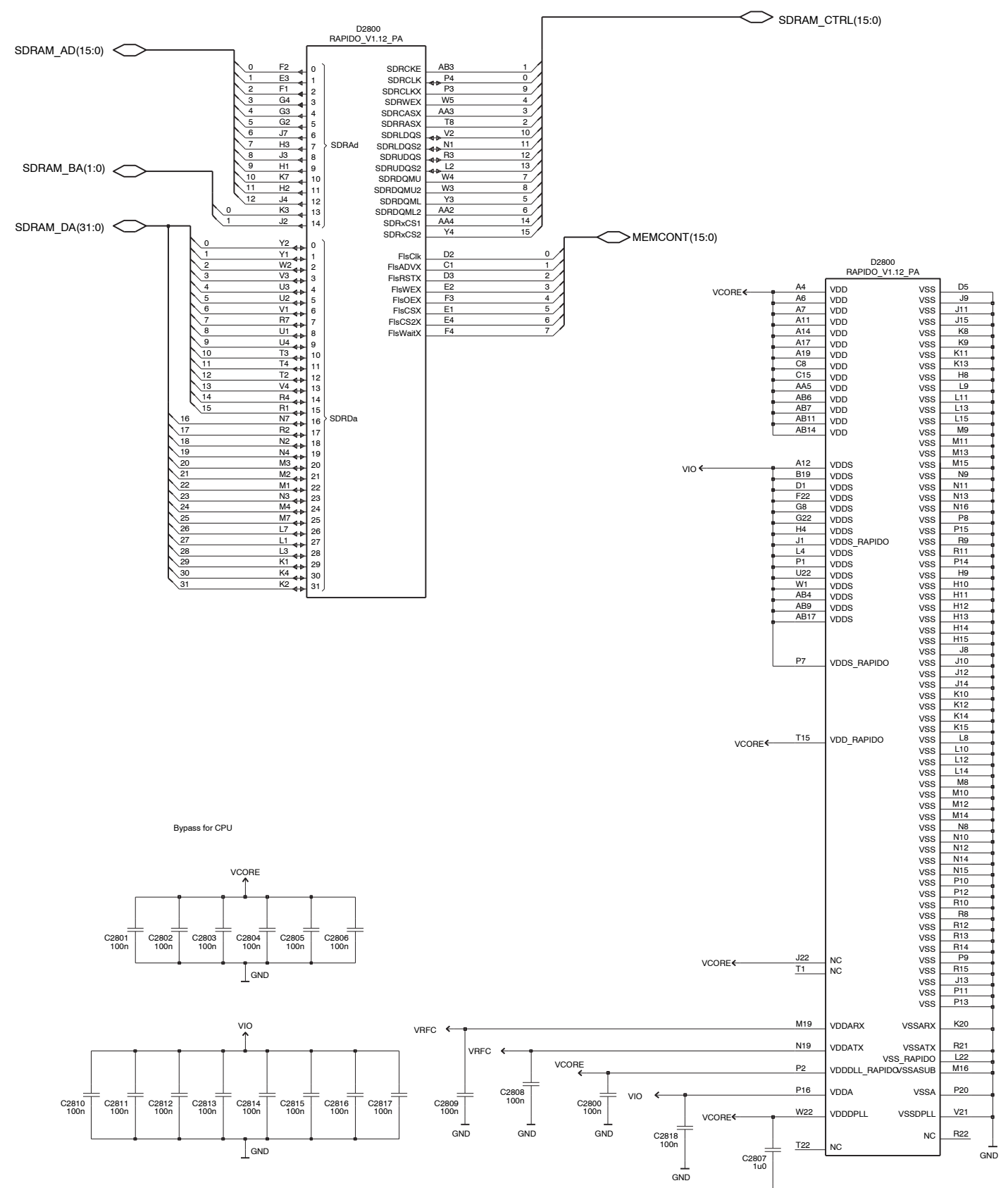
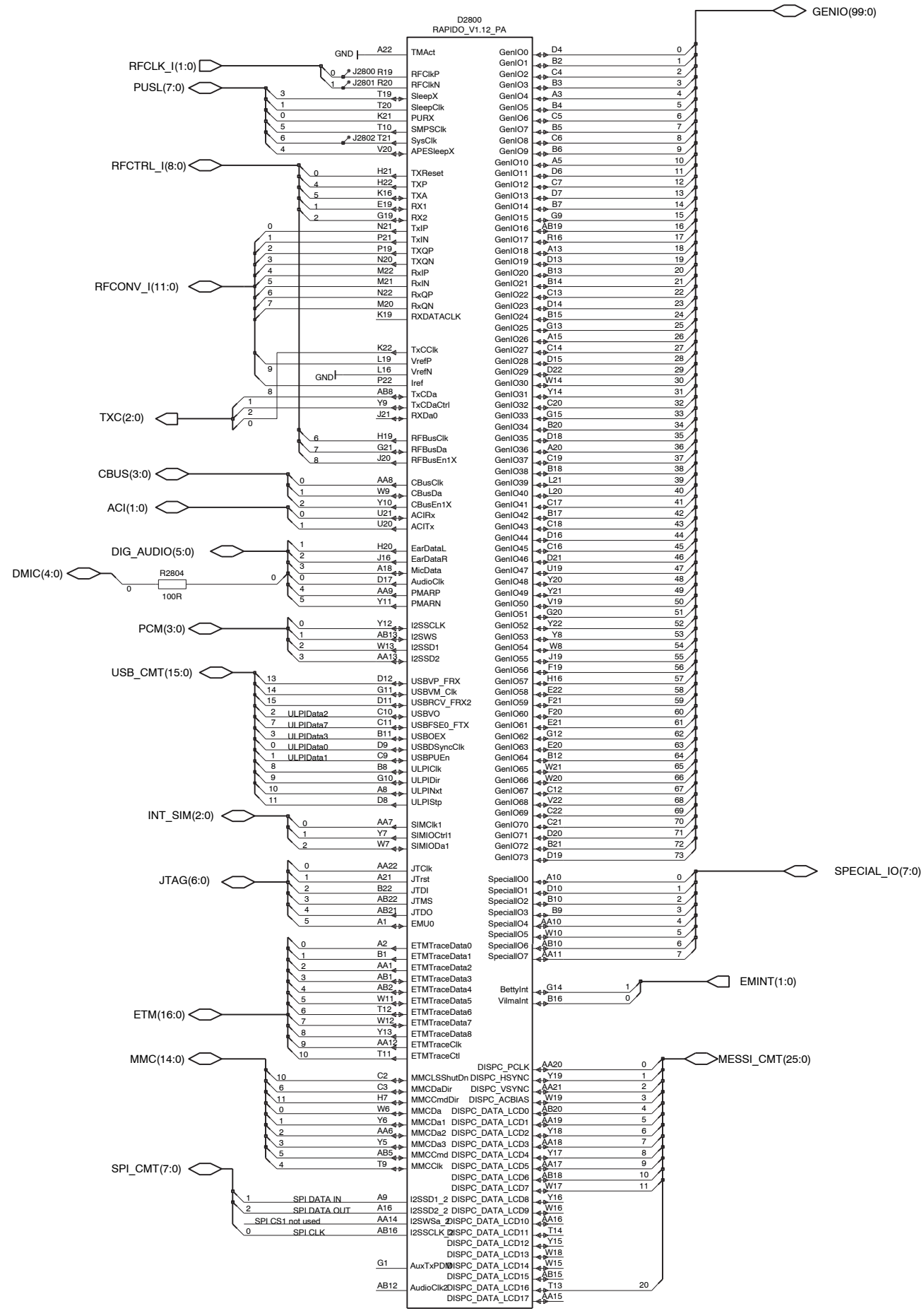

0	genio0	MEMADDA0
1	genio1	MEMADDA1
2	genio2	MEMADDA2
3	genio3	MEMADDA3
4	genio4	MEMADDA4
5	genio5	MEMADDA5
6	genio6	MEMADDA6
7	genio7	MEMADDA7
8	genio8	MEMADDA8
9	genio9	MEMADDA9
10	genio10	MEMADDA10
11	genio11	MEMADDA11
12	genio12	MEMADDA12
13	genio13	MEMADDA13
14	genio14	MEMADDA14
15	genio15	MEMADDA15
16	genio16	IHF_PA_EN
17	genio17	SIGN_PLUG_DET
18	genio18	SIGN_PA_EN
19	genio19	SIGN_DATA_CTRL
20	genio20	FM_INT
21	genio21	BT_WAKEUP
22	genio22	FLASH_INT
23	genio23	KEYB_COLUMN_0
24	genio24	ANT_ST1
25	genio25	ANT_ST2
26	genio26	KEYB_COLUMN_1
27	genio27	CAM_HWA_LDO_STB
28	genio28	AIC33_RESETX
29	genio29	WLAN_IRQ
30	genio30	I2C_SYMB_SDA
31	genio31	I2C_SYMB_SCL
32	genio32	KEYB_ROW_0
33	genio33	KEYB_ROW_1
34	genio34	KEYB_ROW_2
35	genio35	KEYB_ROW_3
36	genio36	KEYB_ROW_4
37	genio37	KEYB_ROW_5
38	genio38	KEYB_ROW_6
39	genio39	KEYB_ROW_7
40	genio40	NAVISCROLL_INT
41	genio41	KEYB_COLUMN_2
42	genio42	DIG_MIC_AUXTPDM
43	genio43	KEYB_COLUMN_3
44	genio44	LCD_RSTX
45	genio45	SD_PREWARNING
46	genio46	MMC_DADIR1
47	genio47	KEY_LOCK_SWITCH
48	genio48	I2C_ISA_SDA
49	genio49	CAM_STV_LDO_EN
50	genio50	BT_HOST_WAKE_UP
51	genio51	I2C_ISA_SCL
52	genio52	POWER_SAVE_LED
53	genio53	KEYB_COLUMN_4
54	genio54	WLAN_RSTX
55	genio55	SLIDE_MR
56	genio56	SLIDE_EL_EN
57	genio57	GAMING_LED_EN
58	genio58	SD_DETECTION
59	genio59	BT_UART_IN
60	genio60	BT_UART_OUT
61	genio61	CAM_REG_EN
62	genio62	SIDE_LEDS_EN
63	genio63	KEYB_COLUMN_5
64	genio64	GAMING_KEY1
65	genio65	BT_RSTX
66	genio66	CAM_STV_PD
67	genio67	GAMING_KEY2
68	genio68	CAM_CLK
69	genio69	BT_CTS
70	genio70	BT_RTS
71	genio71	MMC_FB_CLK
72	genio72	KEYB_COLUMN_6
73	genio73	KEYB_COLUMN_7

SPECIALL_IO(7:0)

0	specialio0	CCP_DAP
1	specialio1	CCP_DAN
2	specialio2	CCP_CLKP
3	specialio3	CCP_CLKN
4	specialio4	AIC33_CLK
5	specialio5	AIC33_WCLK
6	specialio6	AIC33_DOUT
7	specialio7	AIC33_DIN

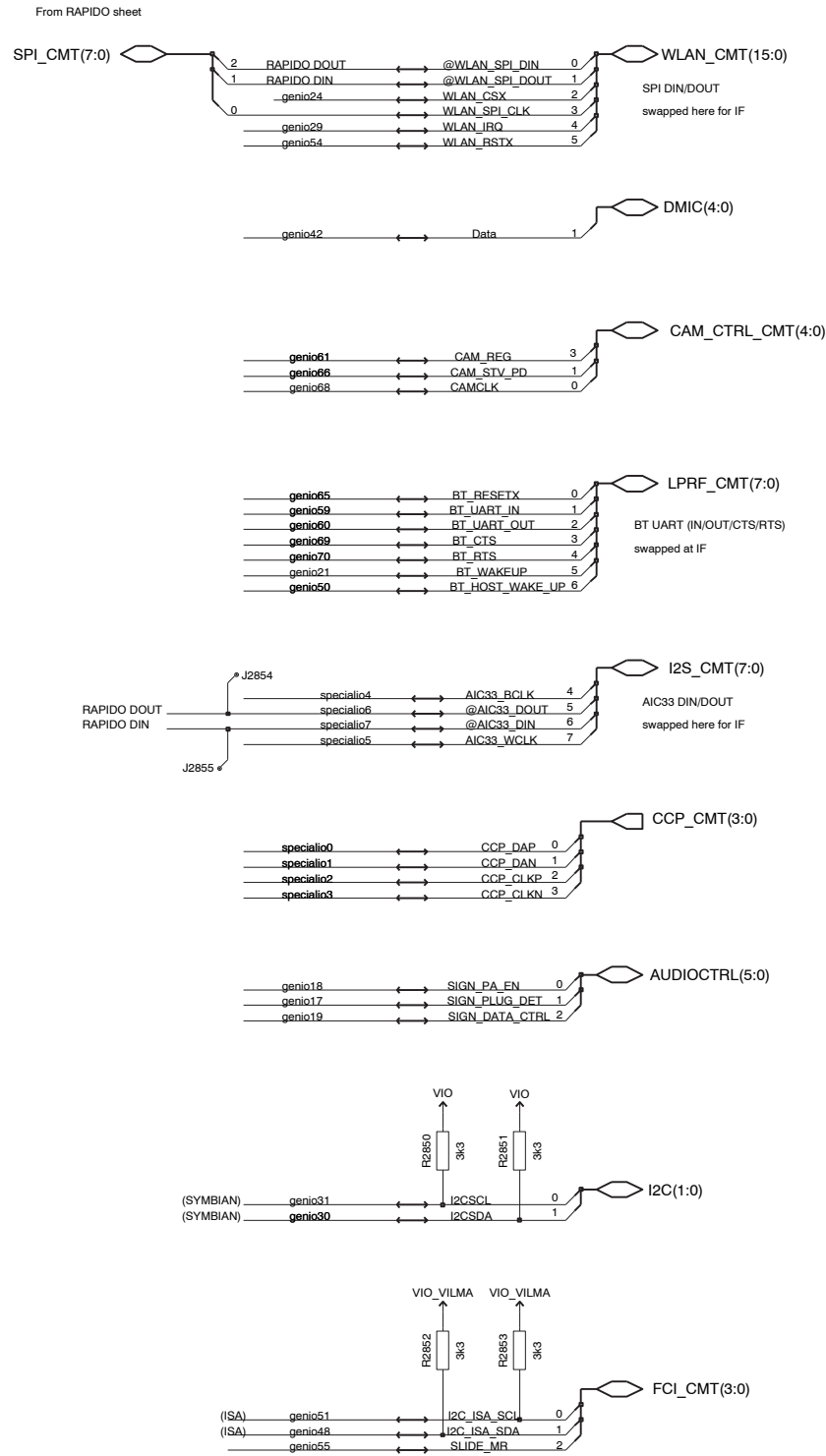

genio0	0
genio1	1
genio2	2
genio3	3
genio4	4
genio5	5
genio6	6
genio7	7
genio8	8
genio9	9
genio10	10
genio11	11
genio12	12
genio13	13
genio14	14
genio15	15

MEMADDA(24:0)

genio22 → FLASH_INT 10

MEMCONT(15:0)

genio46	7
genio58	9
genio45	12
genio71	13

MMC(14:0)

genio32	0
genio33	1
genio34	2
genio35	3
genio36	4
genio37	5
genio38	6
genio39	7
genio23	8
genio26	9
genio41	10
genio43	11
genio53	12
genio63	13
genio72	14
genio73	15

KEYB_CMT(20:0)

genio49	0
genio27	1
genio64	2
genio67	3
genio20	5
genio44	6
genio52	7
genio57	8
genio56	9
genio25	11
genio16	12
genio28	13
genio40	14
genio47	15
genio62	16

GEN_CTRL_CMT(20:0)

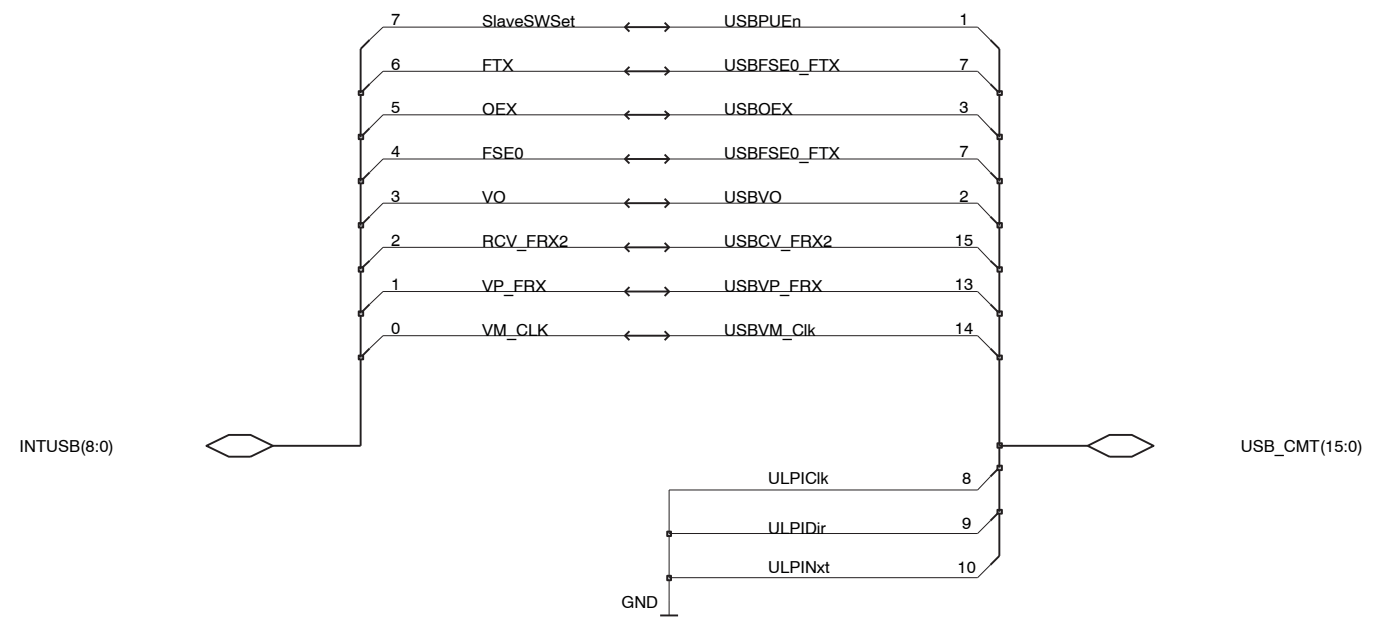

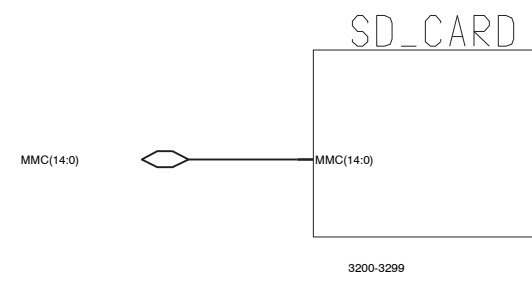
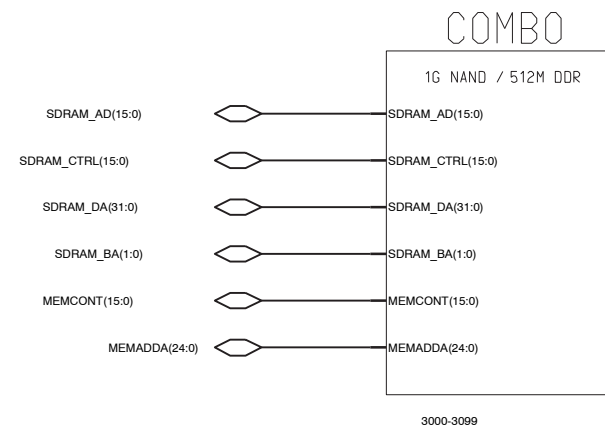

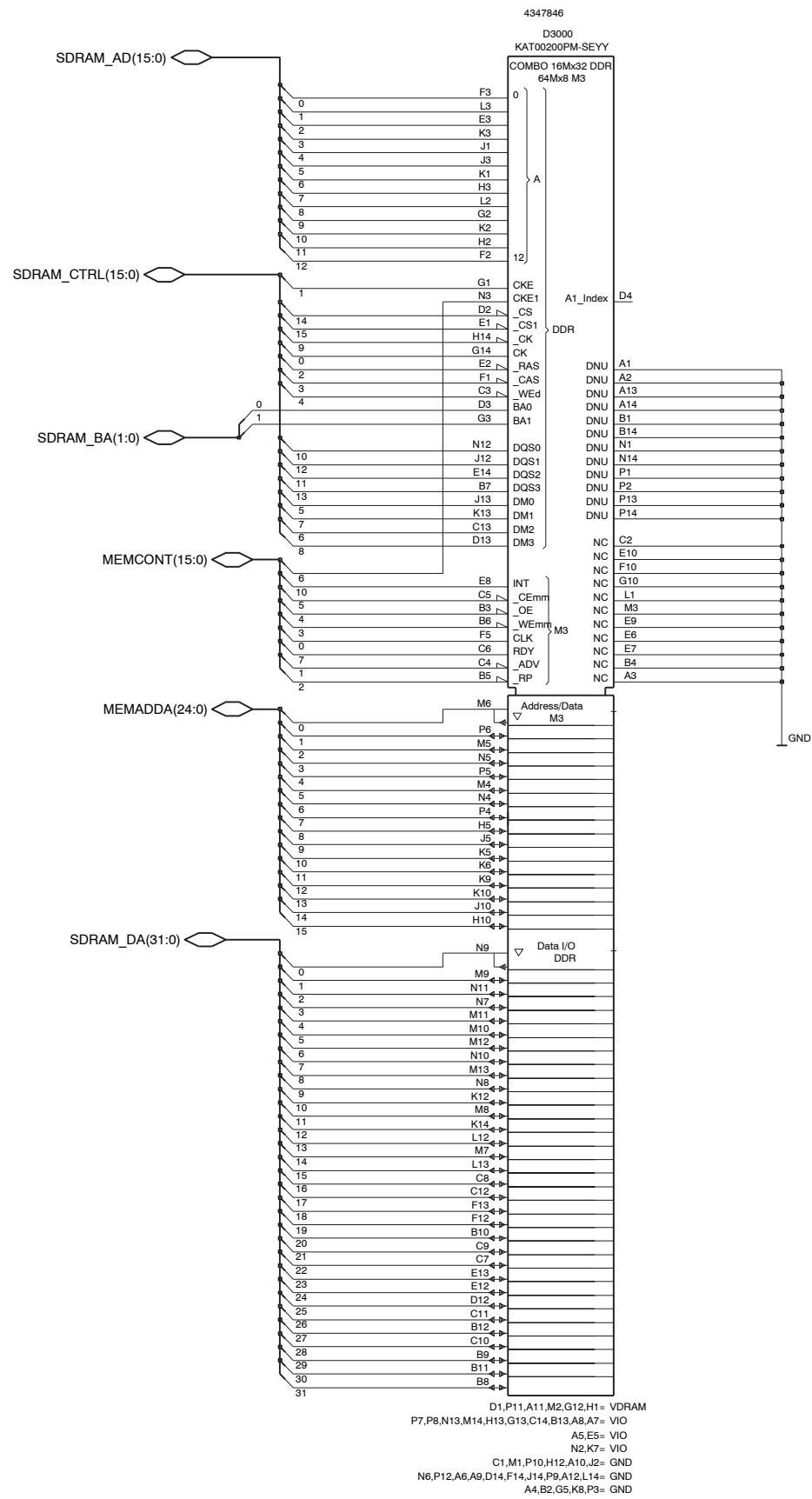
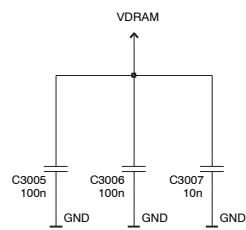
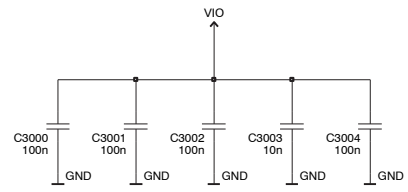

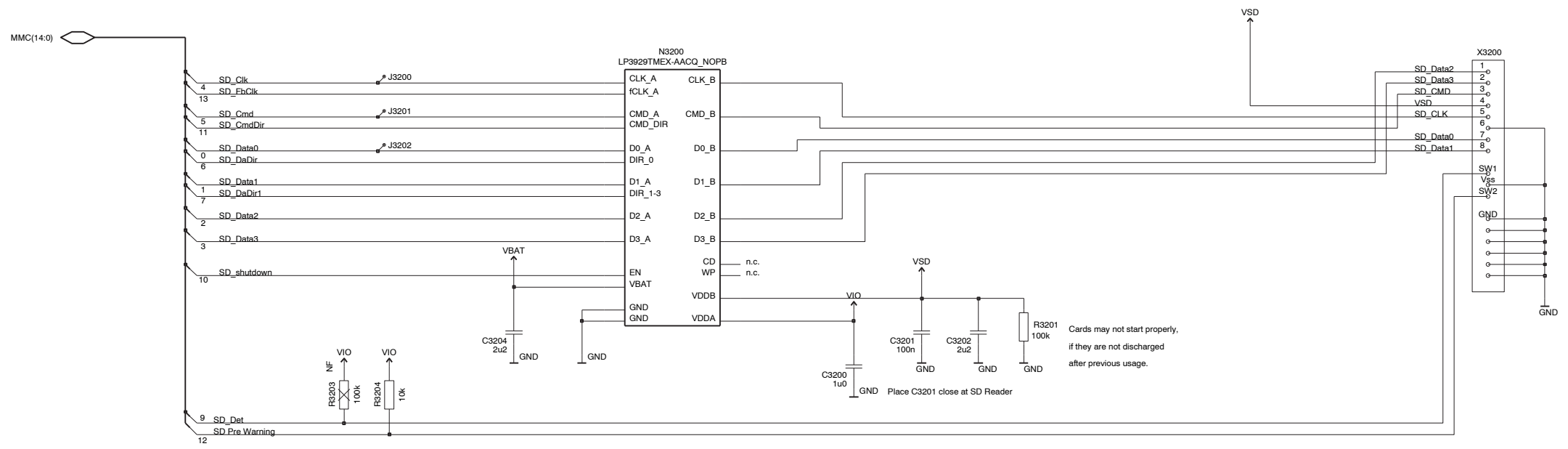

CBB5X

TOP SHEET

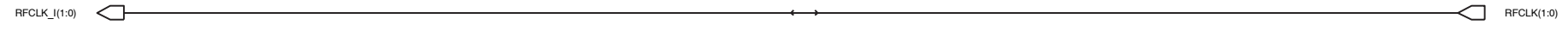

Own CLK on Wlan-sheet

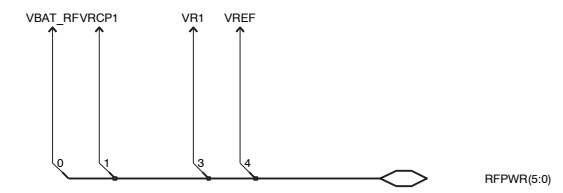

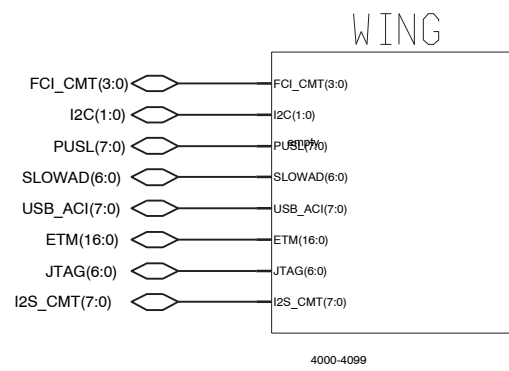
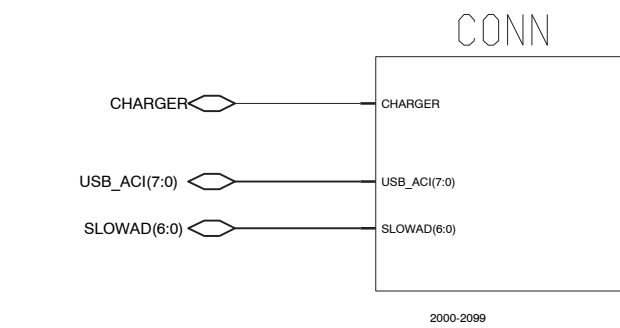
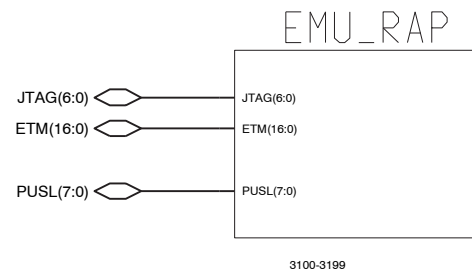
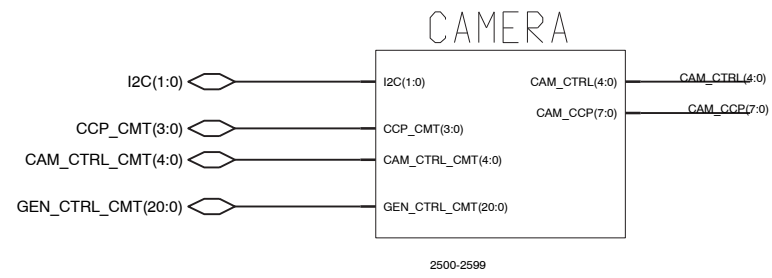
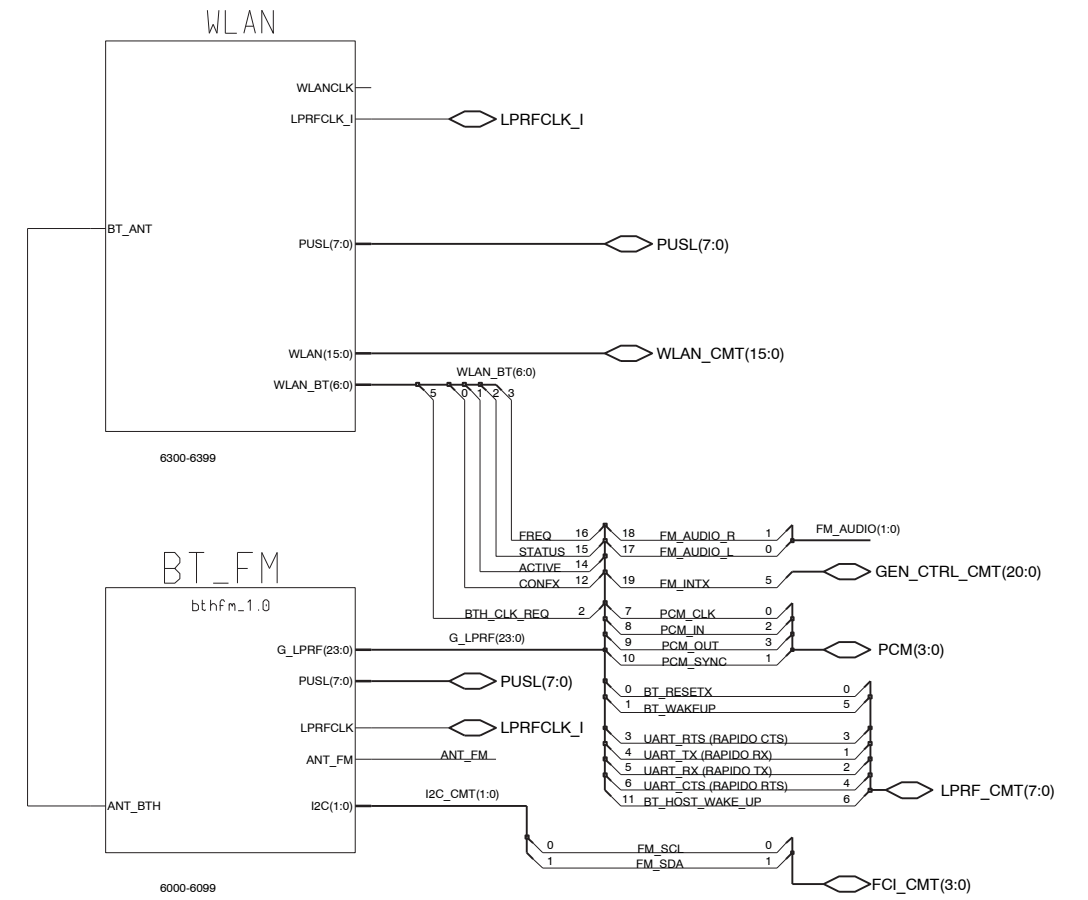
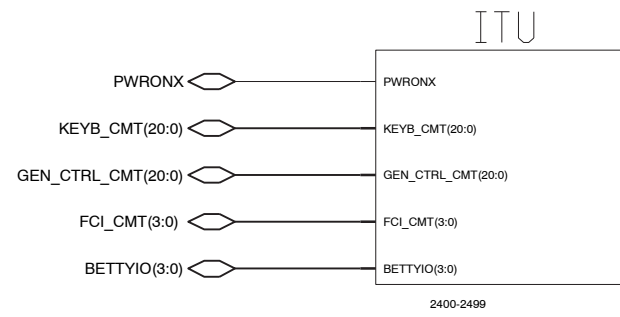
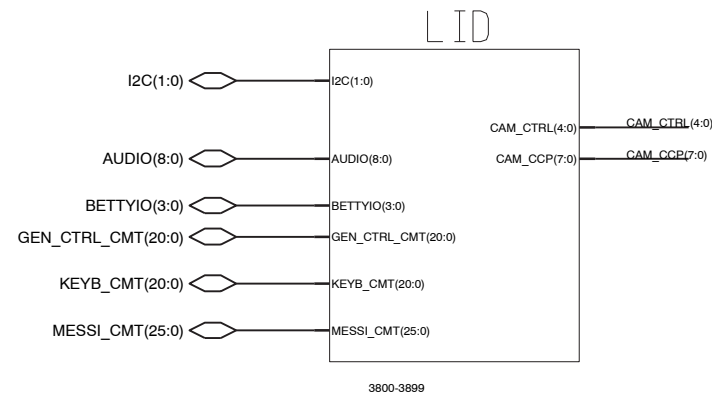
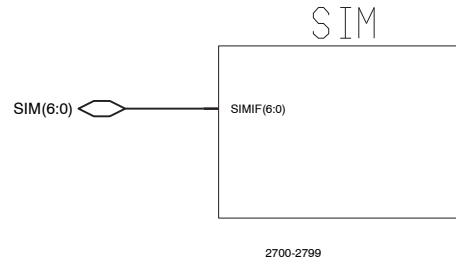
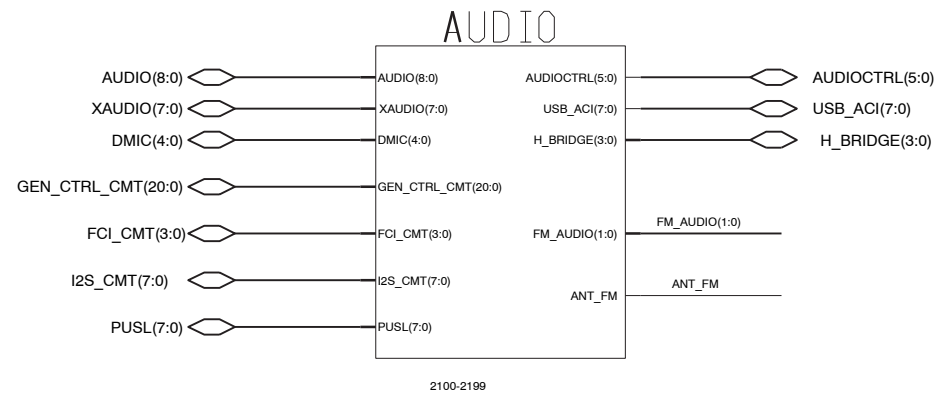

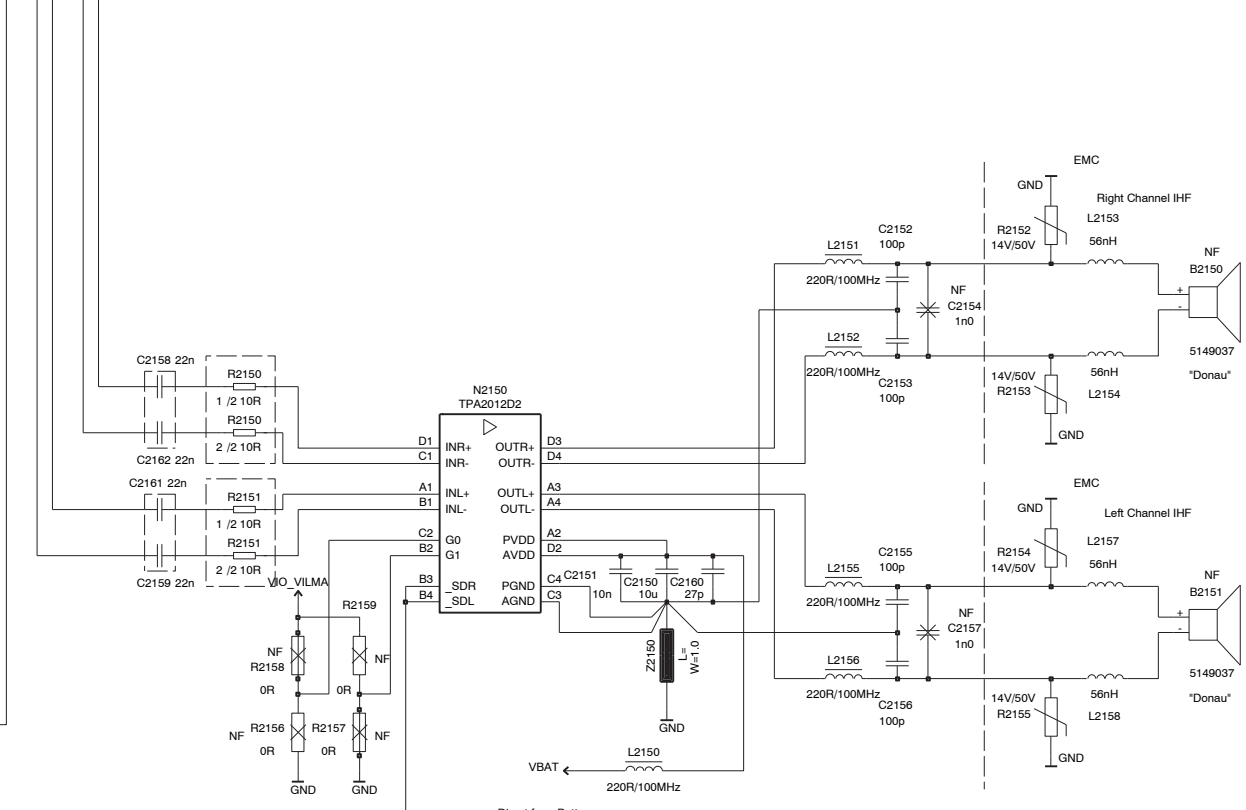
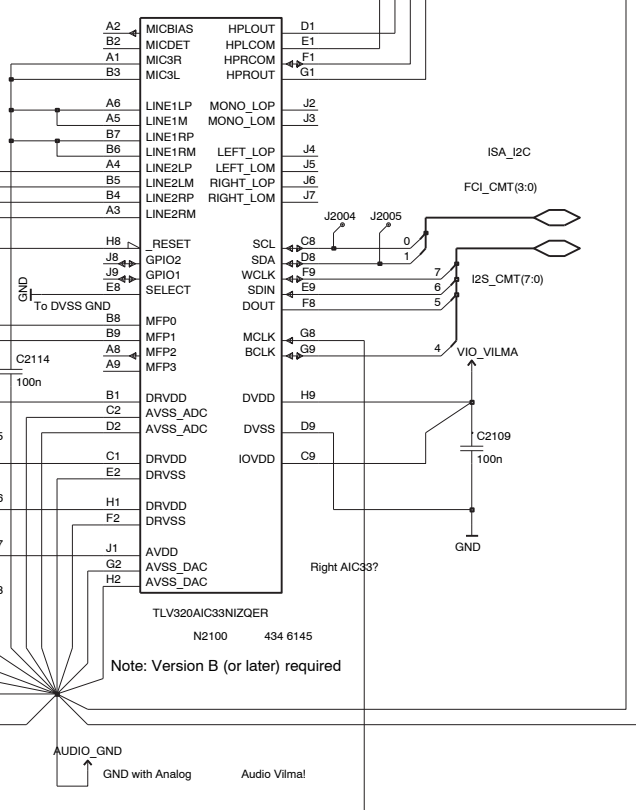
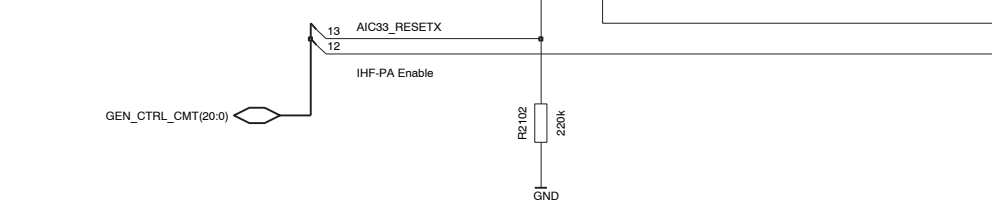
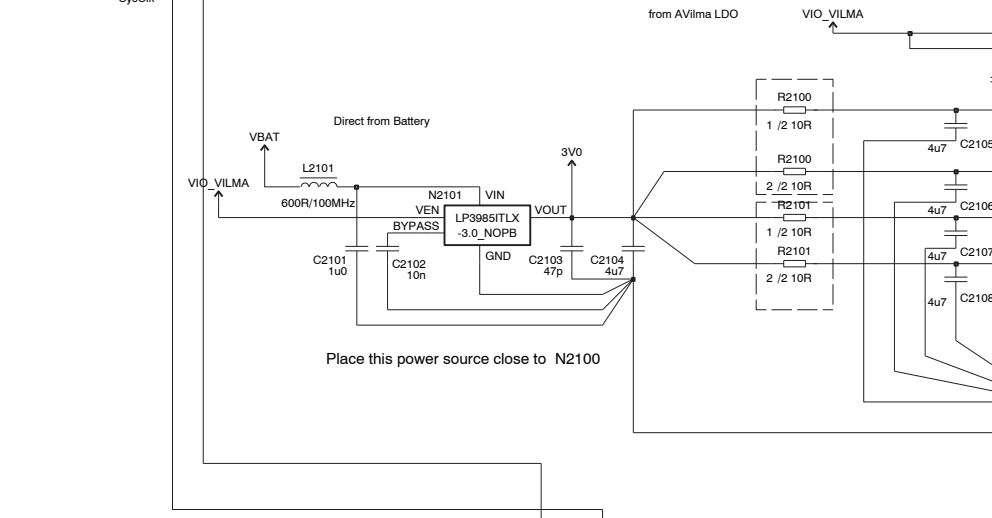
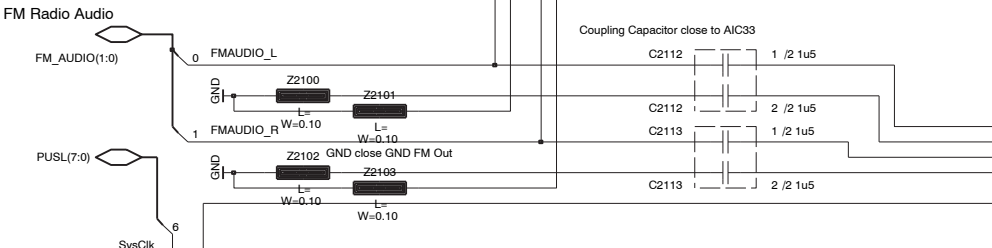
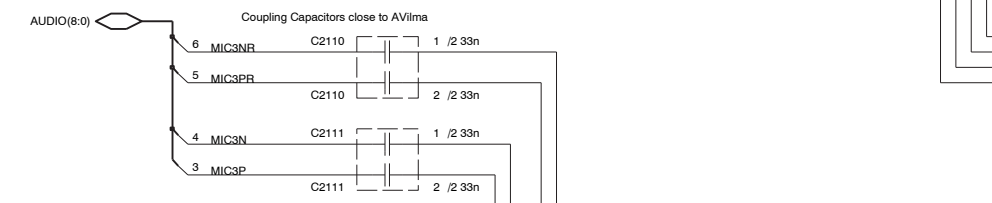
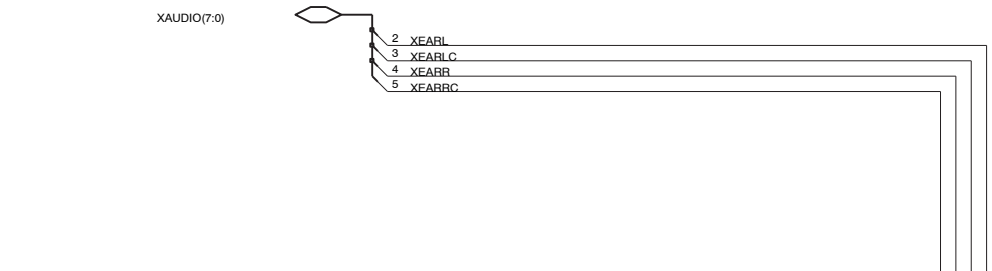
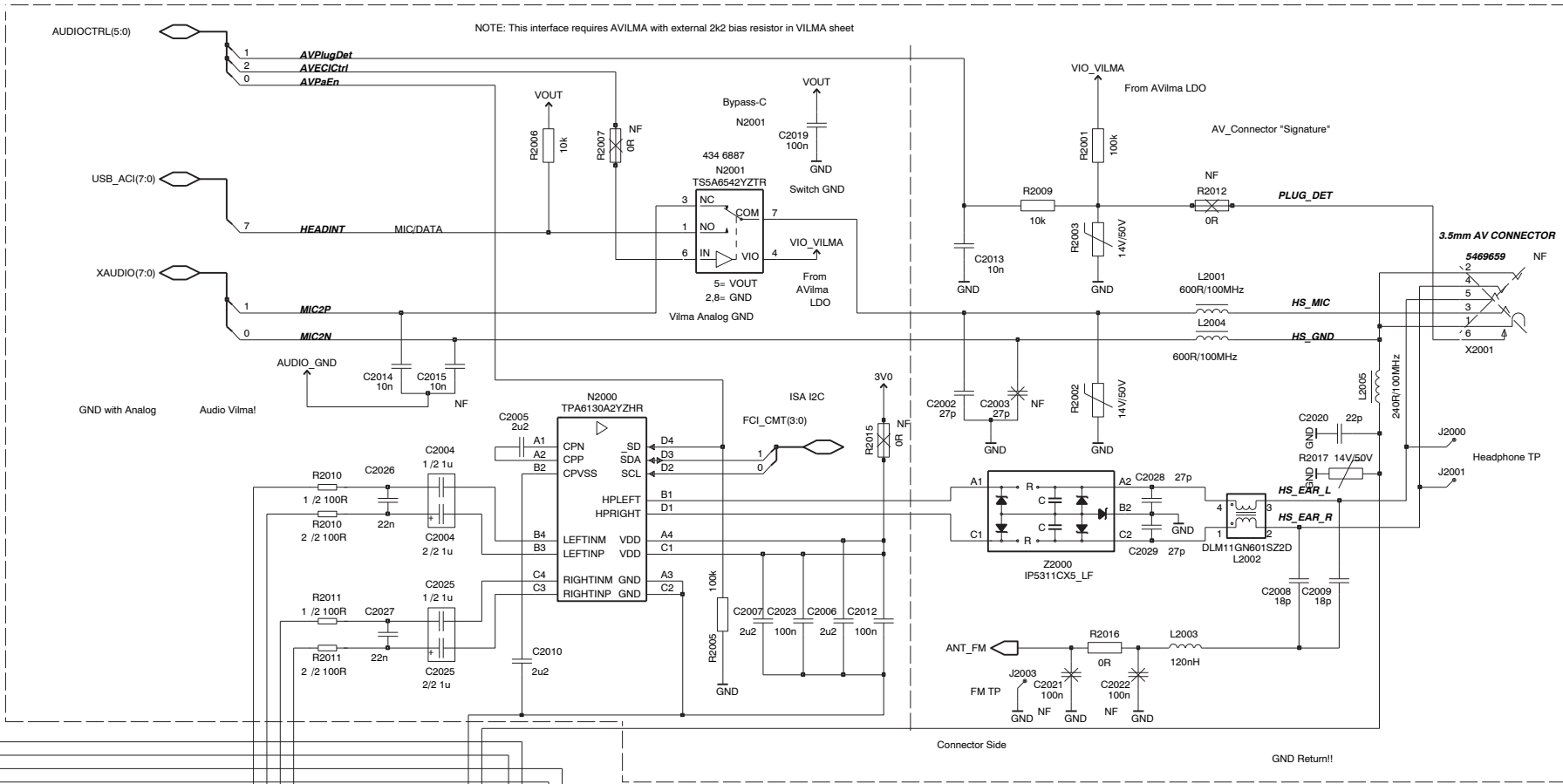
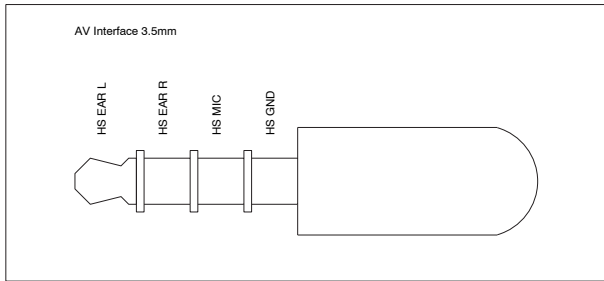

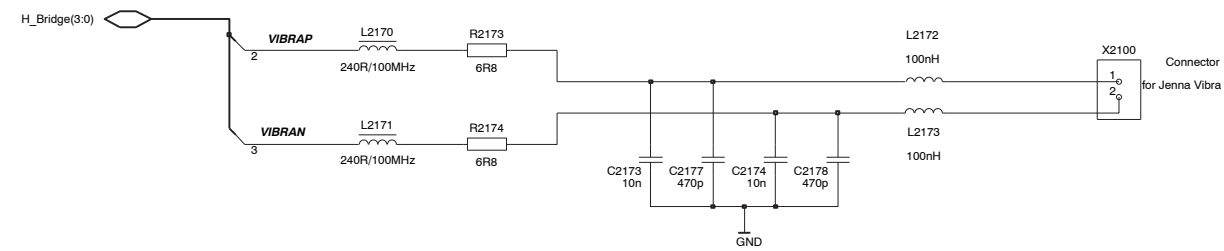
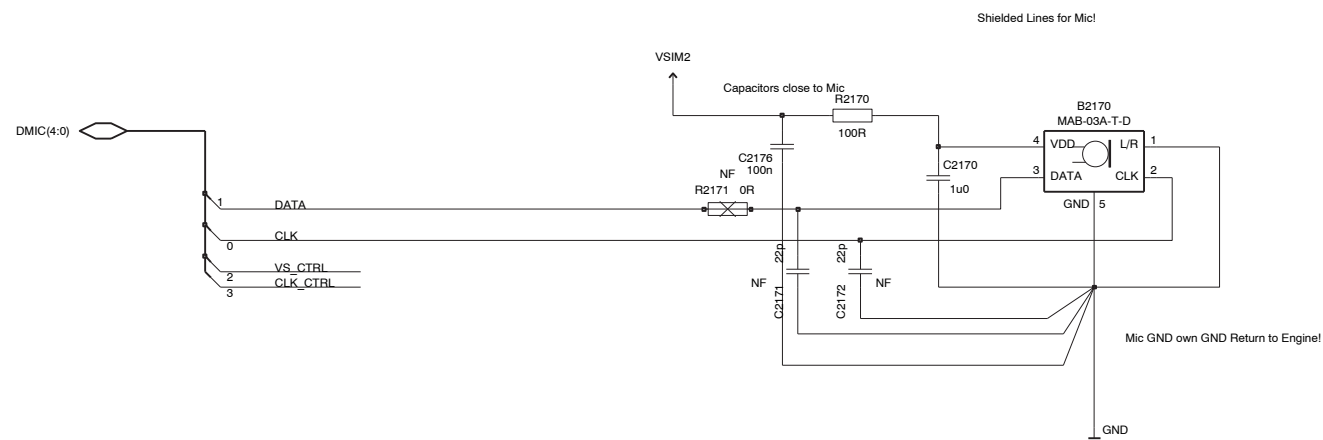

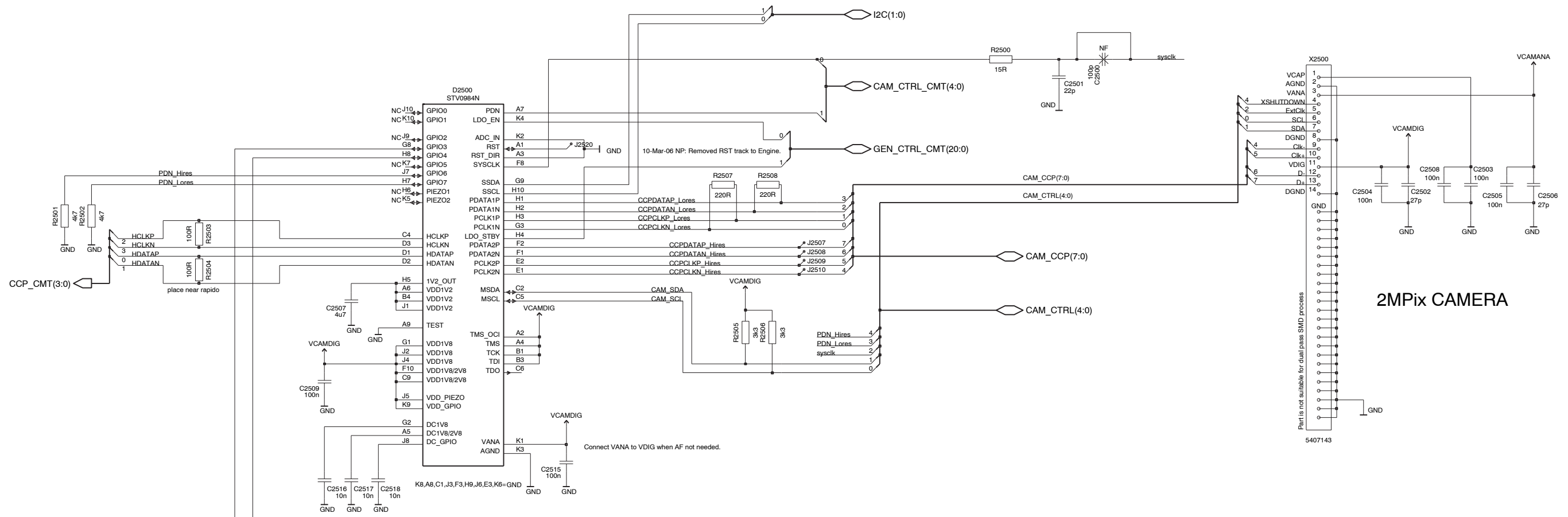

2MPiX CAMERA

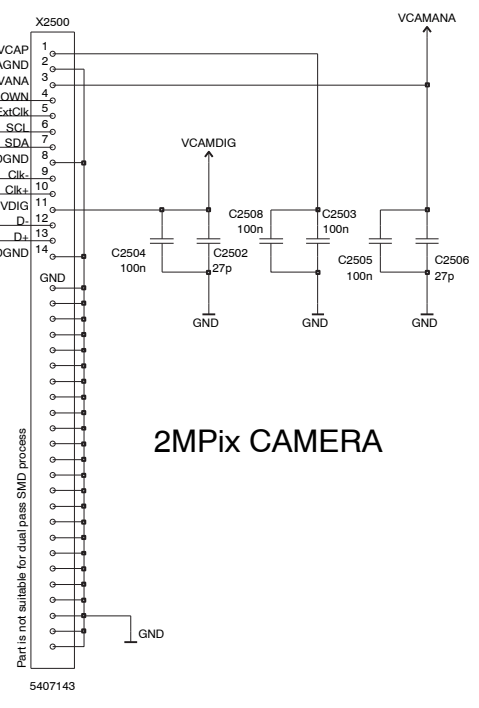

Flash LED

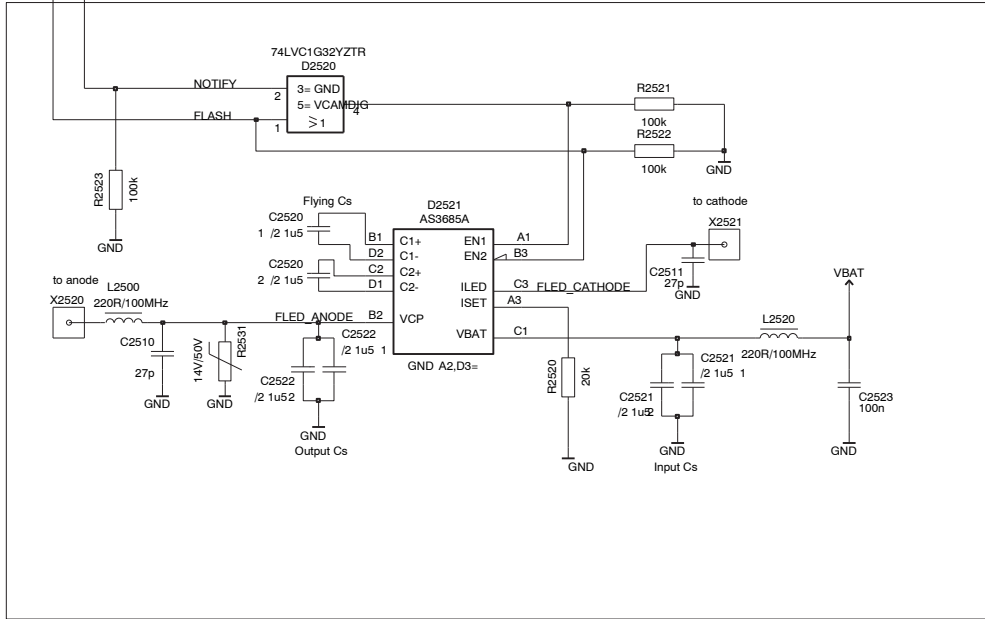

Camera Power Supplis

