

Service Schematics

NOKIA E60

Introduction

RM-49



Exploded view and component disposal

IMPORTANT:

This document is intended for use by authorized NOKIA service centers only.

“Service Schematics was created with focus on customer care. The purpose of this document is to provide further technical repair information for NOKIA mobile phones on Level 3/4 service activities. It contains additional information such as e.g. “Component finder”, “Frequency band table” or “Antenna switch table”. The “Signal overview” page gives a good and fast overview about the most important signals and voltages on board. Saving process time and improving the repair quality is the aim of this document. It is to be used additionally to the service manual and other training or service information such as Service Bulletins.

All measurements were made using following equipment:

Nokia repair SW	: Phoenix version 2005.44.5.120
Oscilloscope	: Fluke PM 3380A/B
Spectrum Analyzer	: Advantest R3162 with an analog probe
RF-Generator / GSM Tester	: Rhode & Schwarz CMU 200
Multimeter	: Fluke 73 Series II

While every endeavour has been made to ensure the accuracy of this document, some errors may exist. If the reader finds any errors, NOKIA shall be notified in writing.

Please send E-Mail to: training.sace@nokia.com

Table of Contents	Page
Front page	1
System connector	2
RETU	3
TAHVO	4
RAP3G, Memories	5
HELEN, MMC, Combo memory	6
UI	7
Bluetooth	8
WLAN	9
RF-part	10
Signal overview	11
Component finder	12

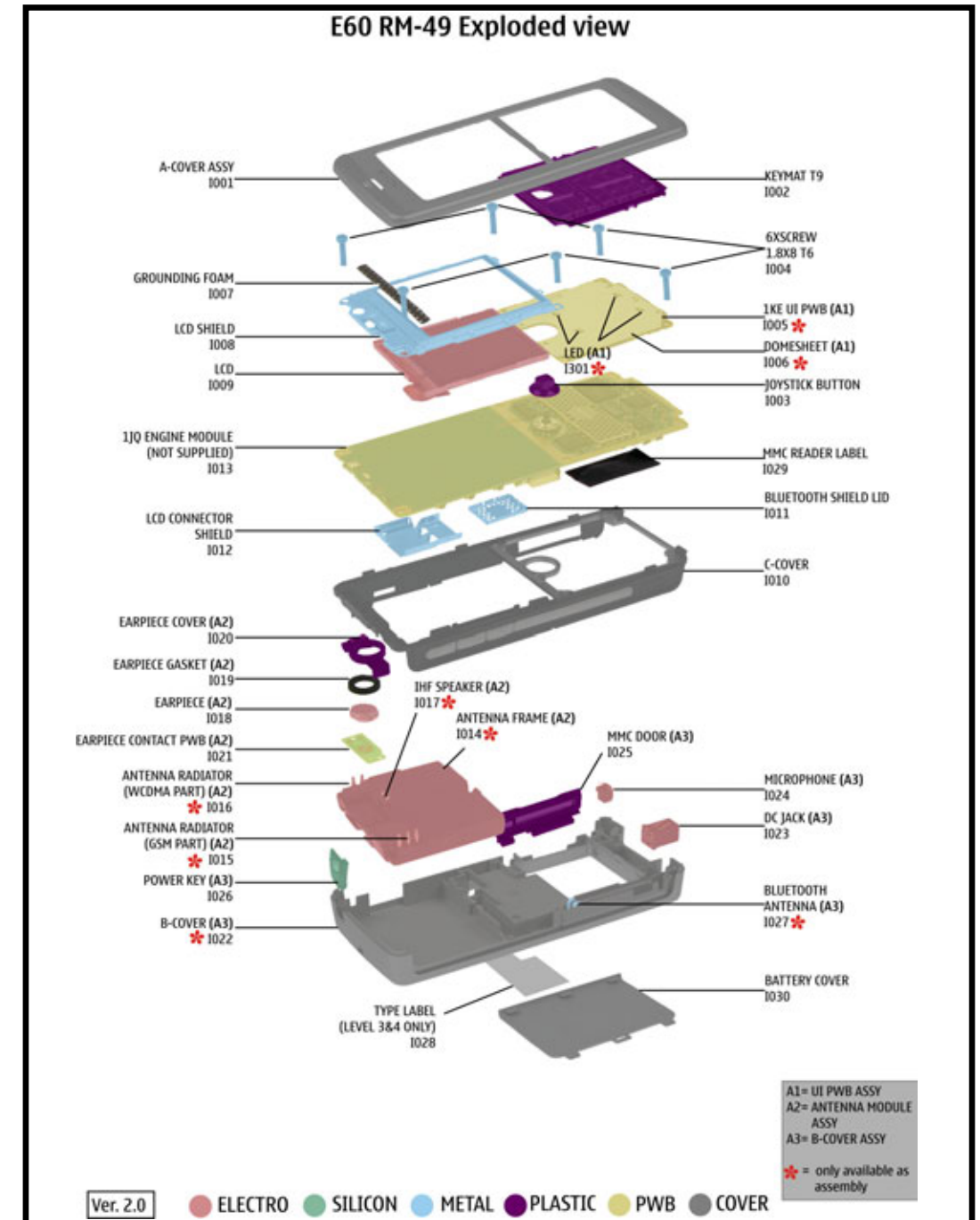

Copyright © NOKIA

This material, including documentation and any related computer programs is protected by copyright, controlled by NOKIA. All rights are reserved. Copying, including reproducing, modifying, storing, adapting or translating any or all of this material requires the prior written consent of NOKIA. This material also contains company confidential information, which may not be disclosed to others without the prior written consent of NOKIA.

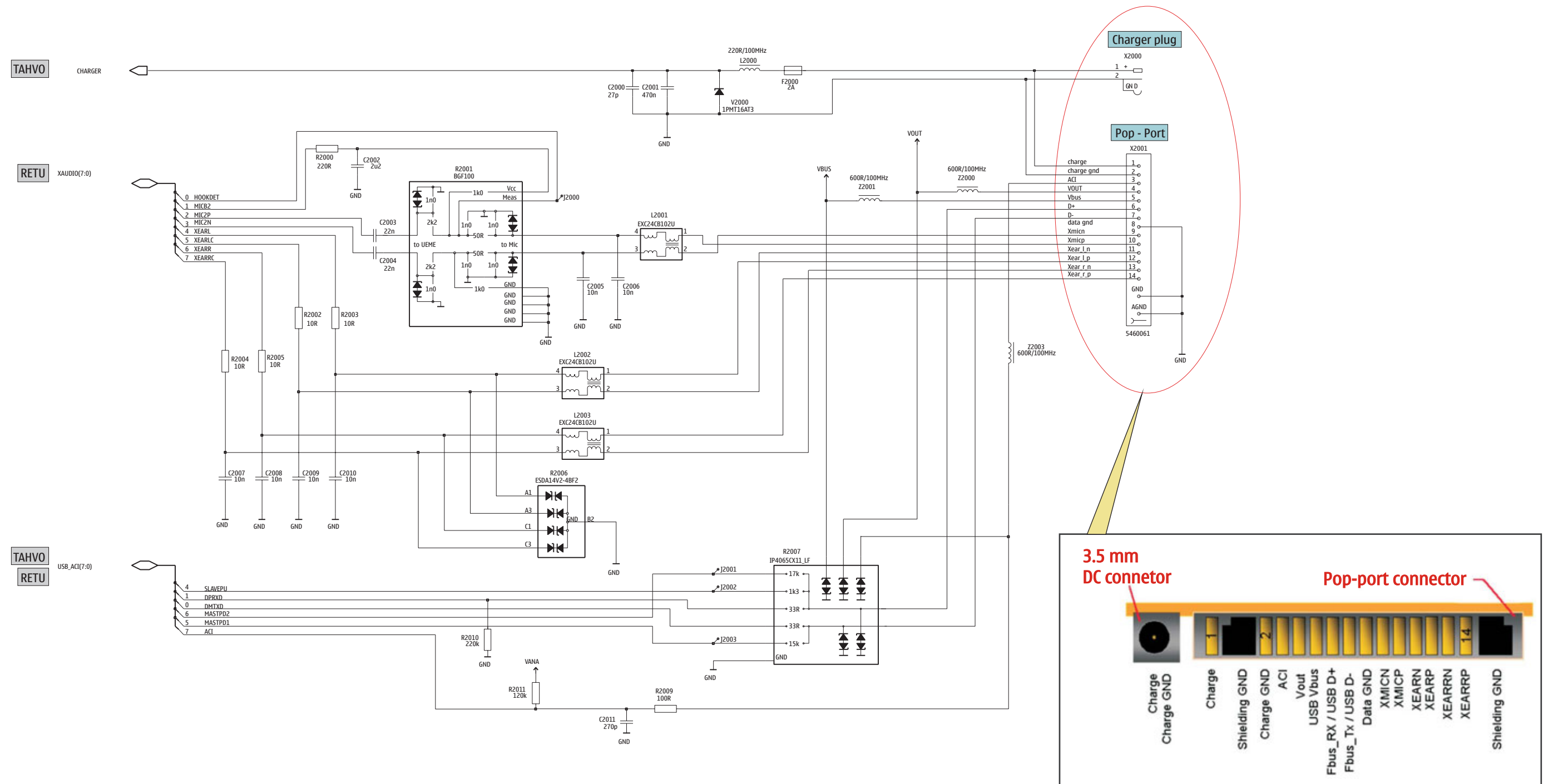

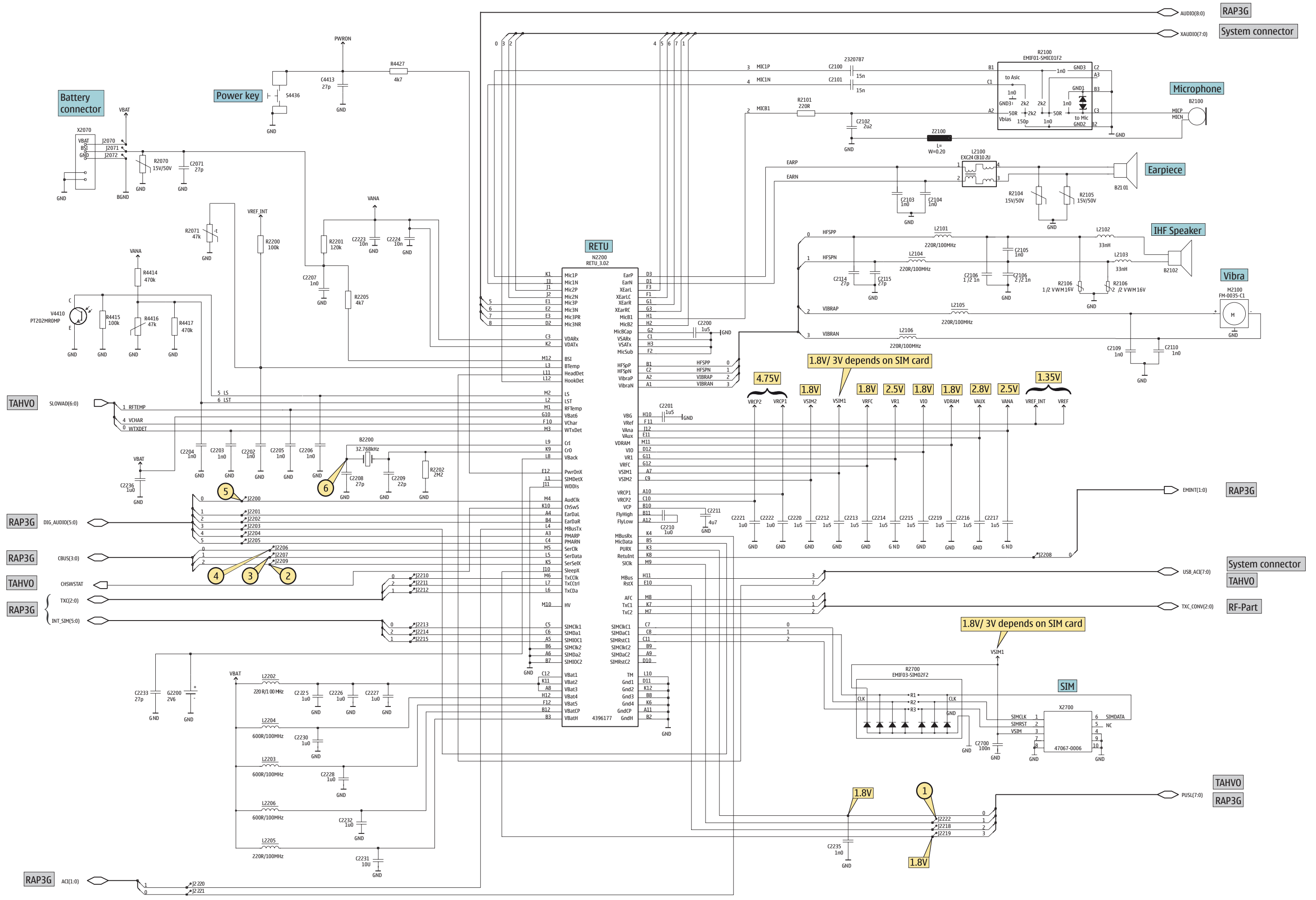

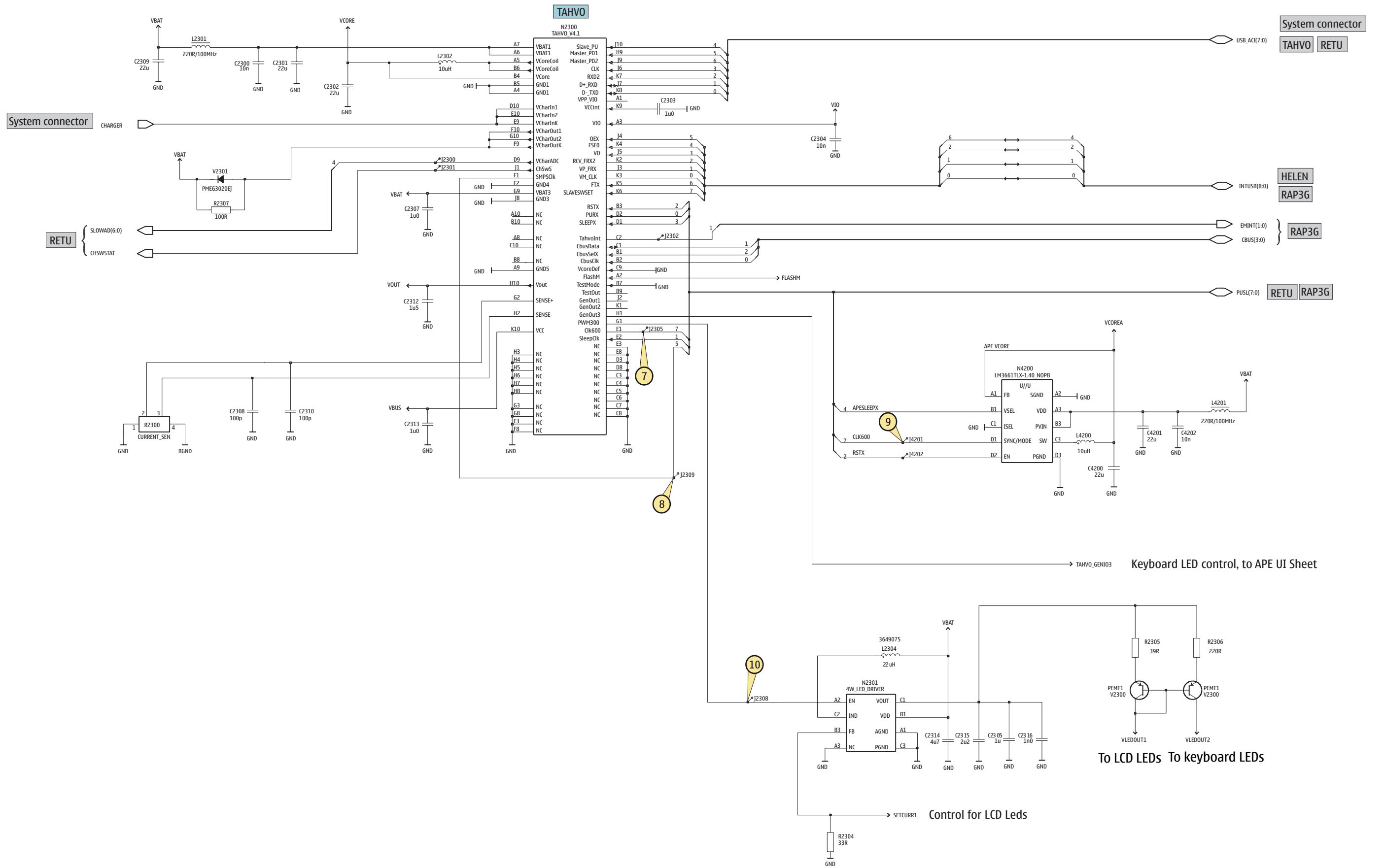

Keyboard LED control, to APE UI Sheet

To LCD LEDs To keyboard LEDs

Control for LCD Leds

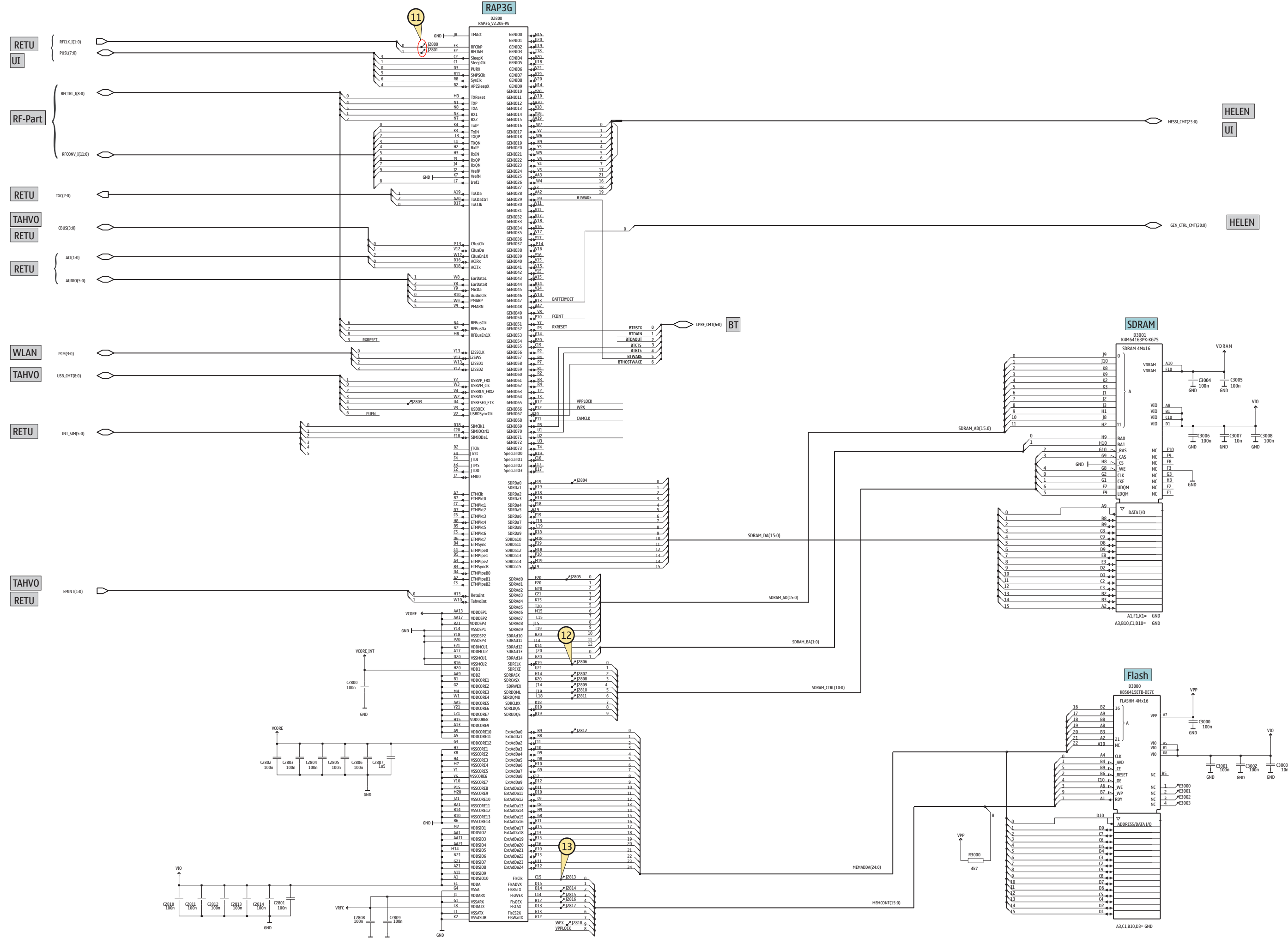

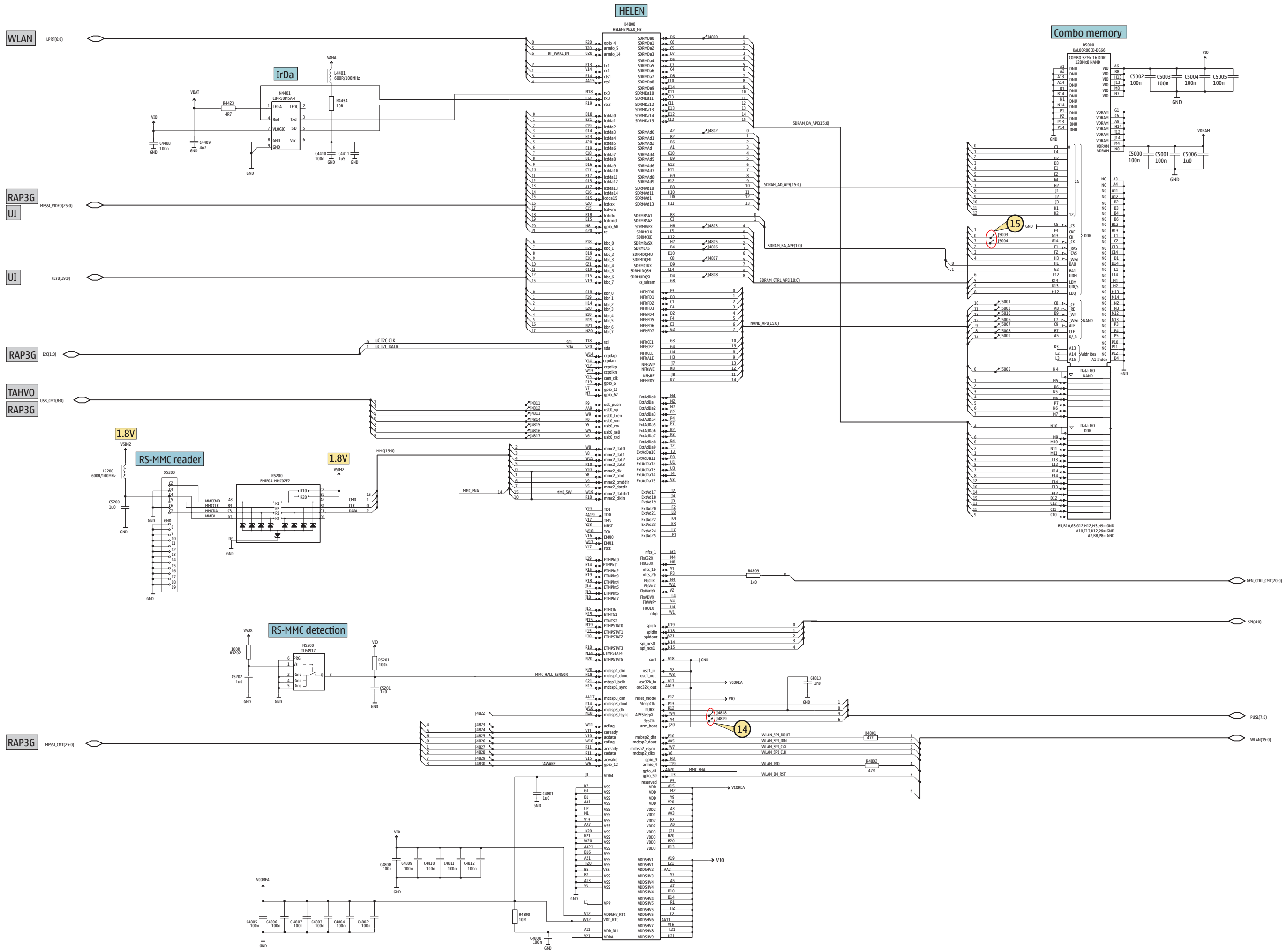

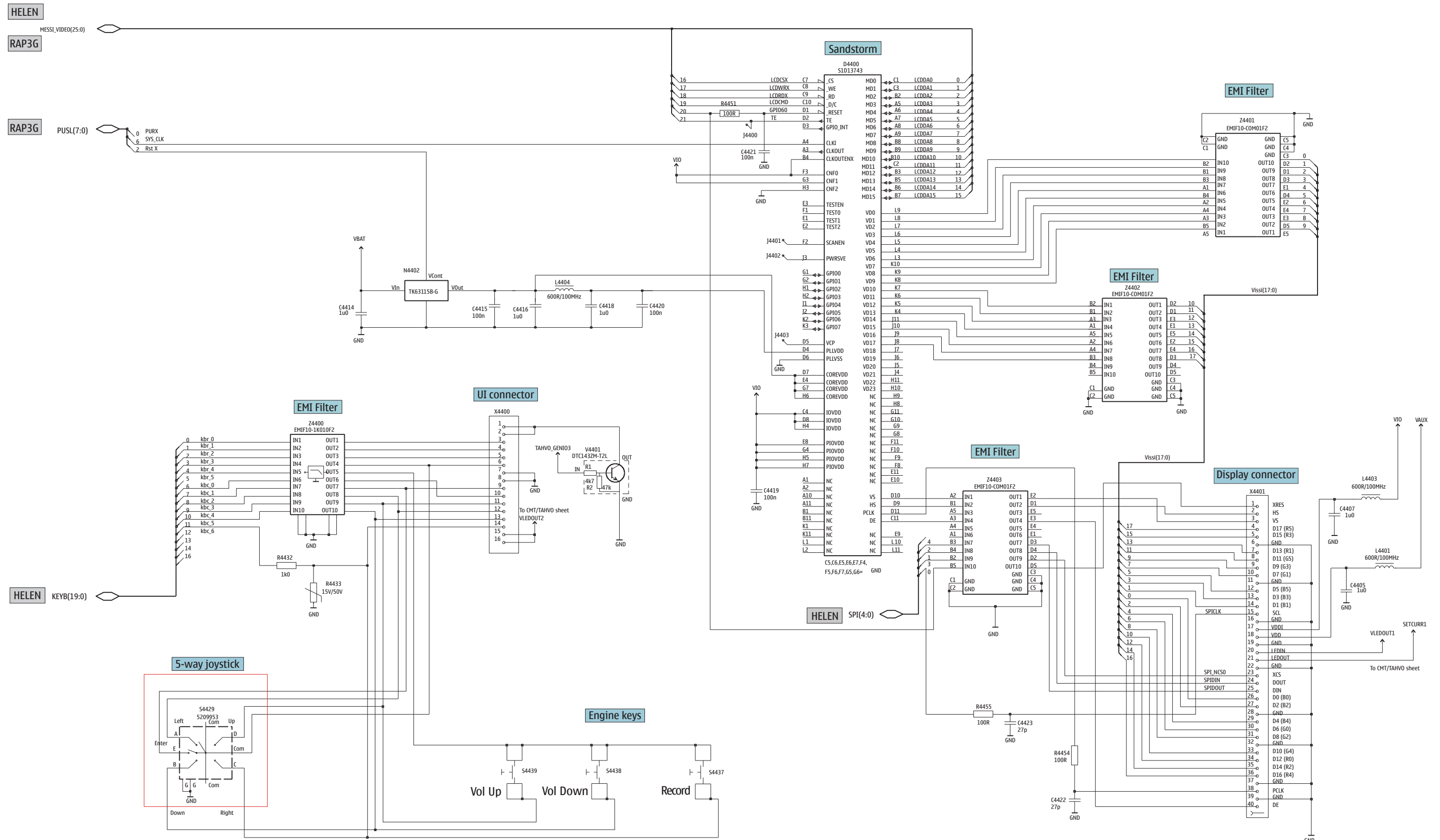

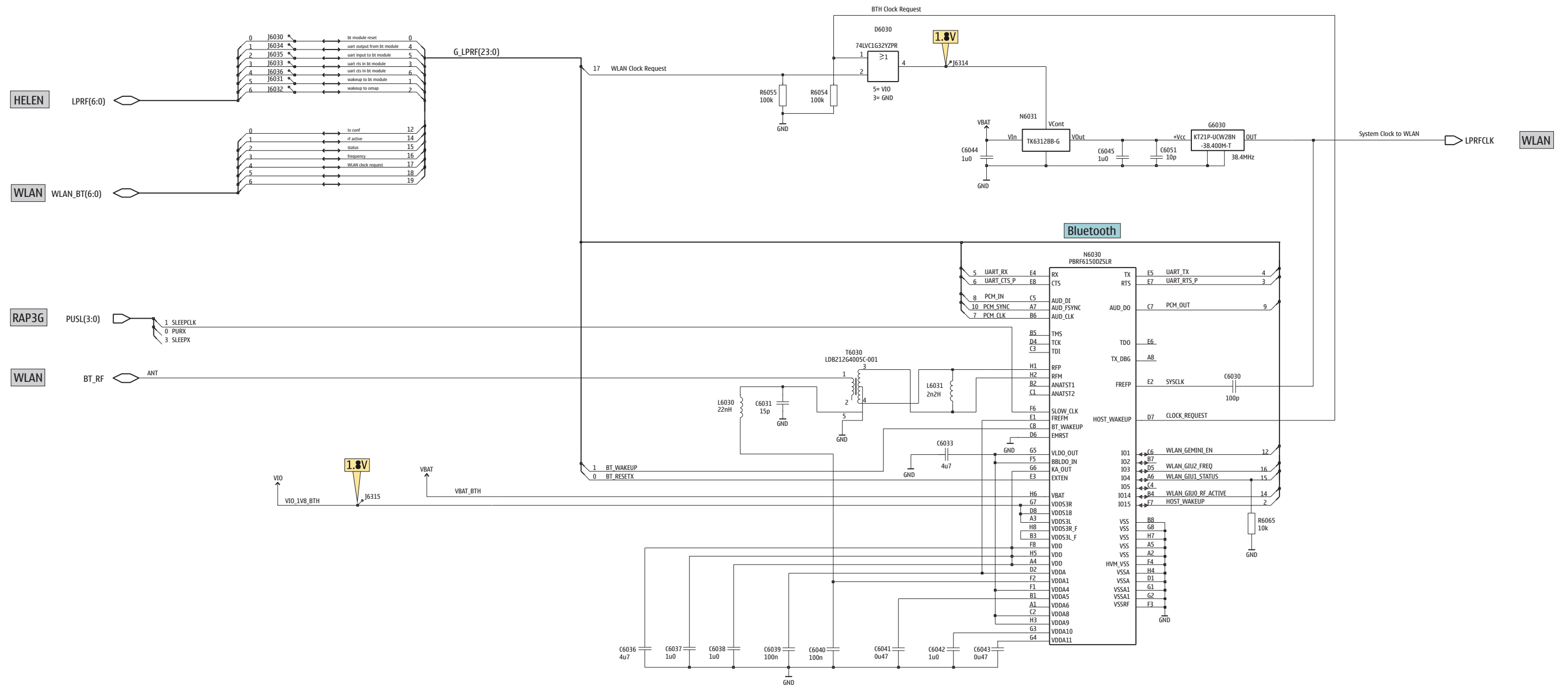

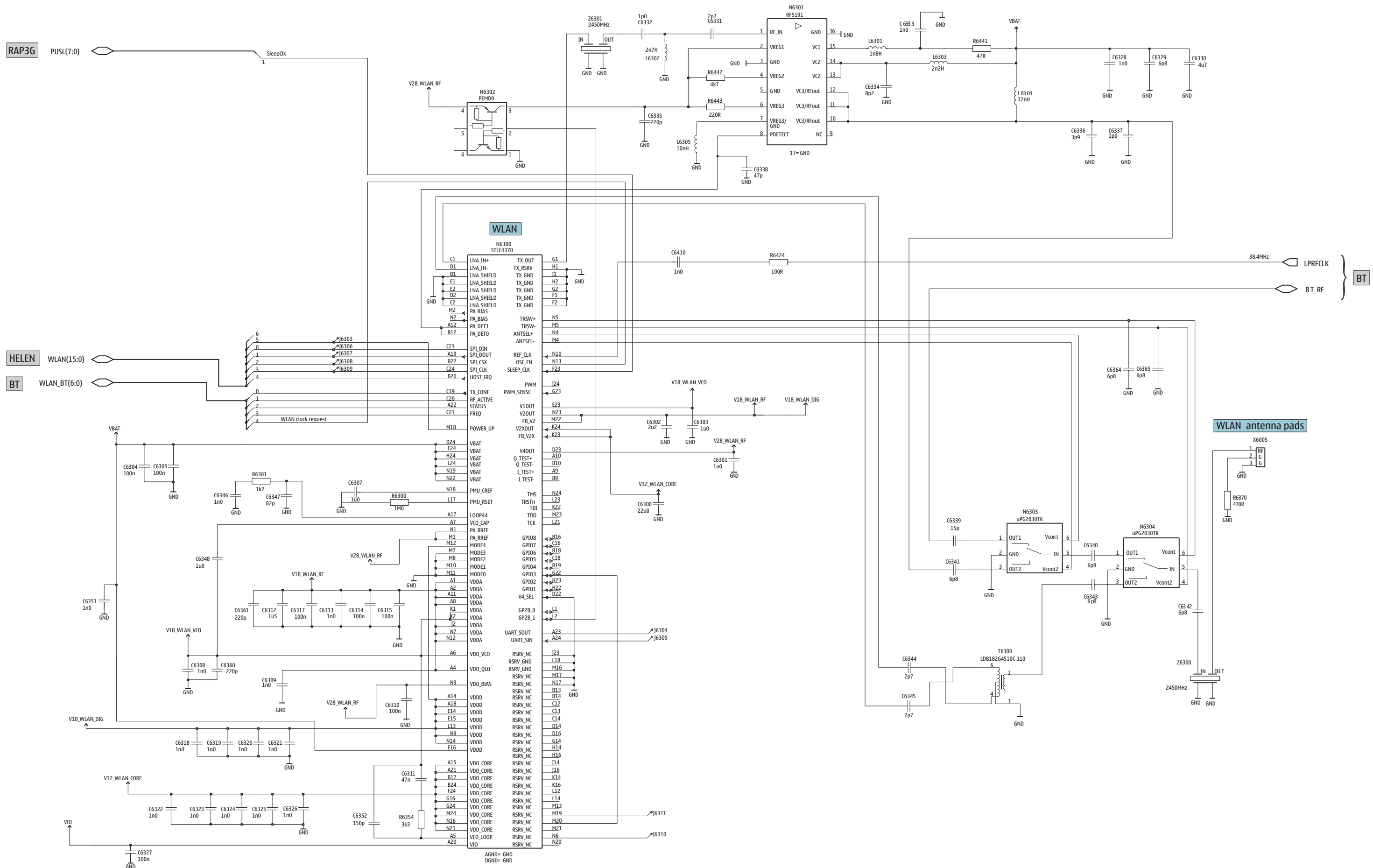

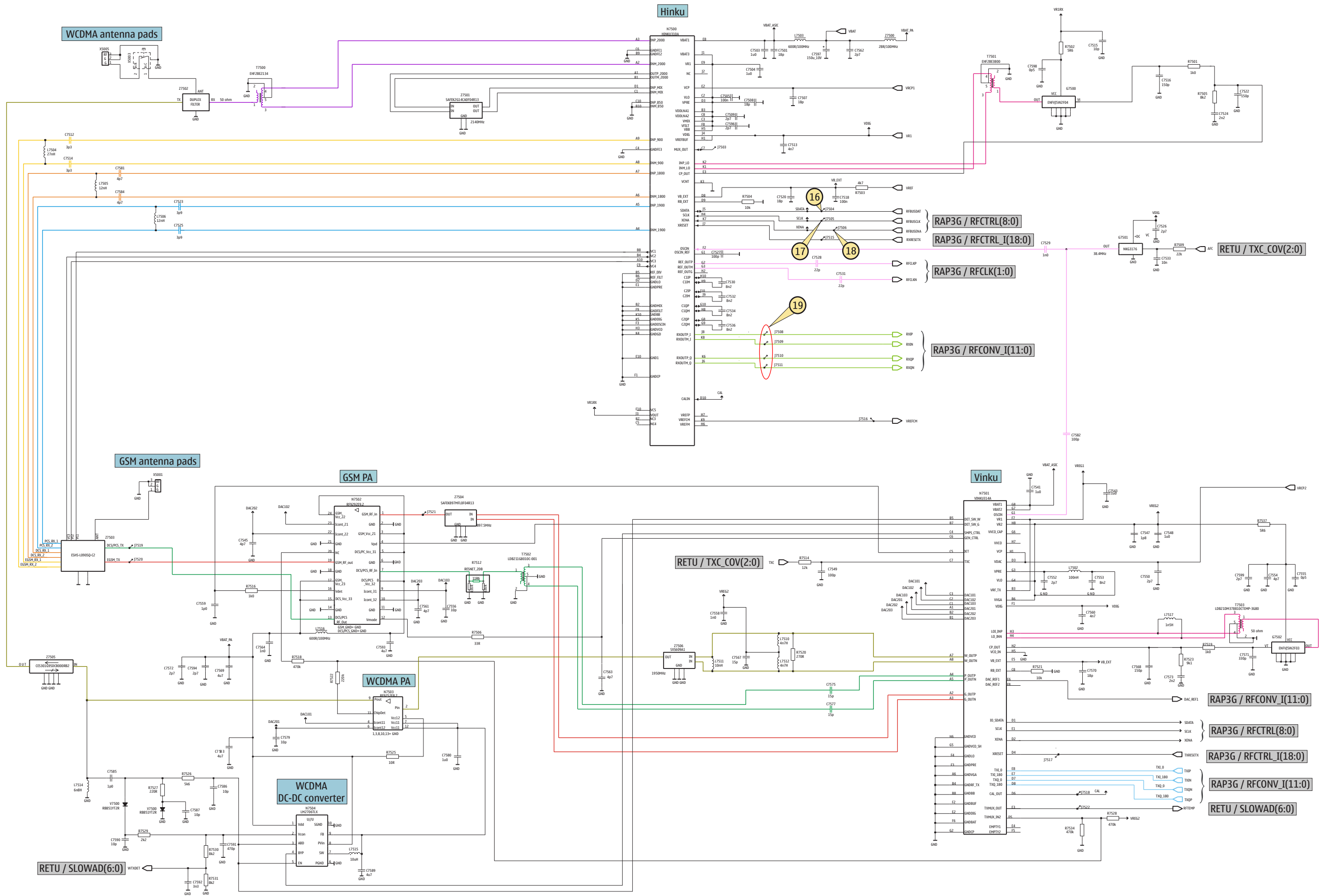

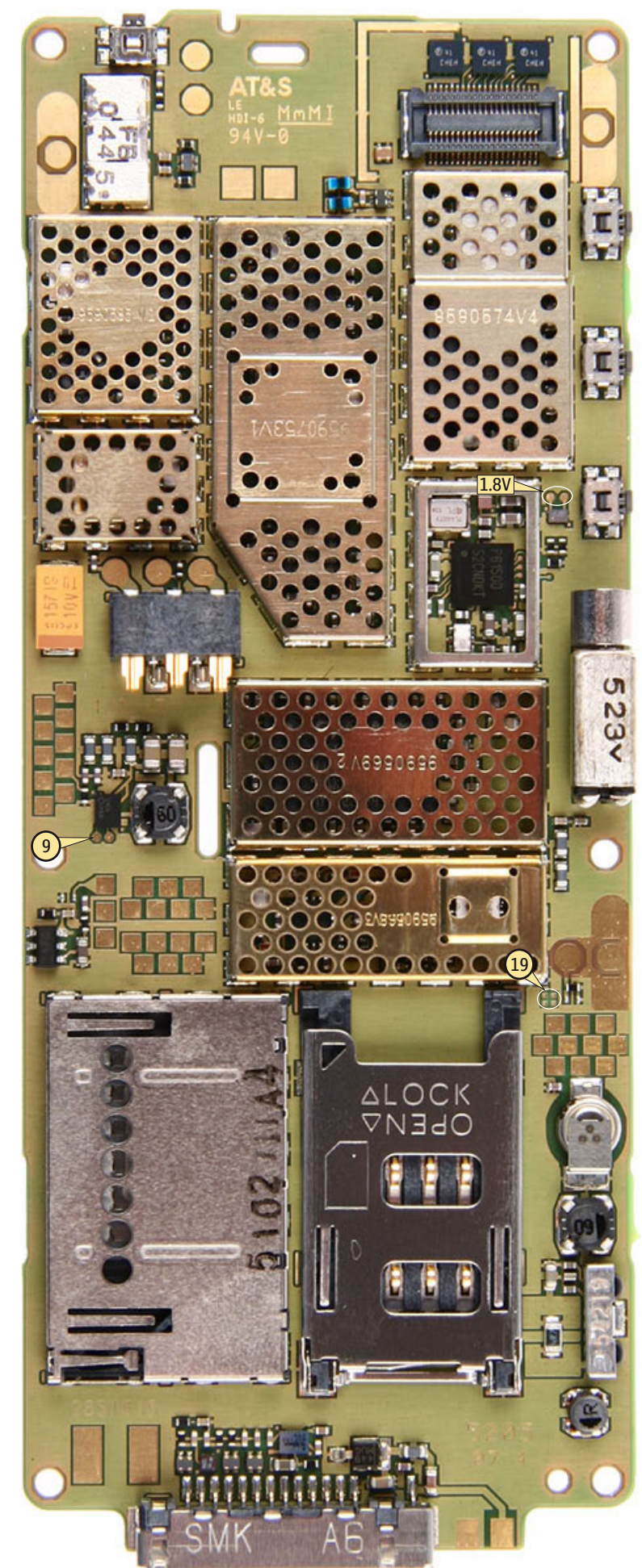
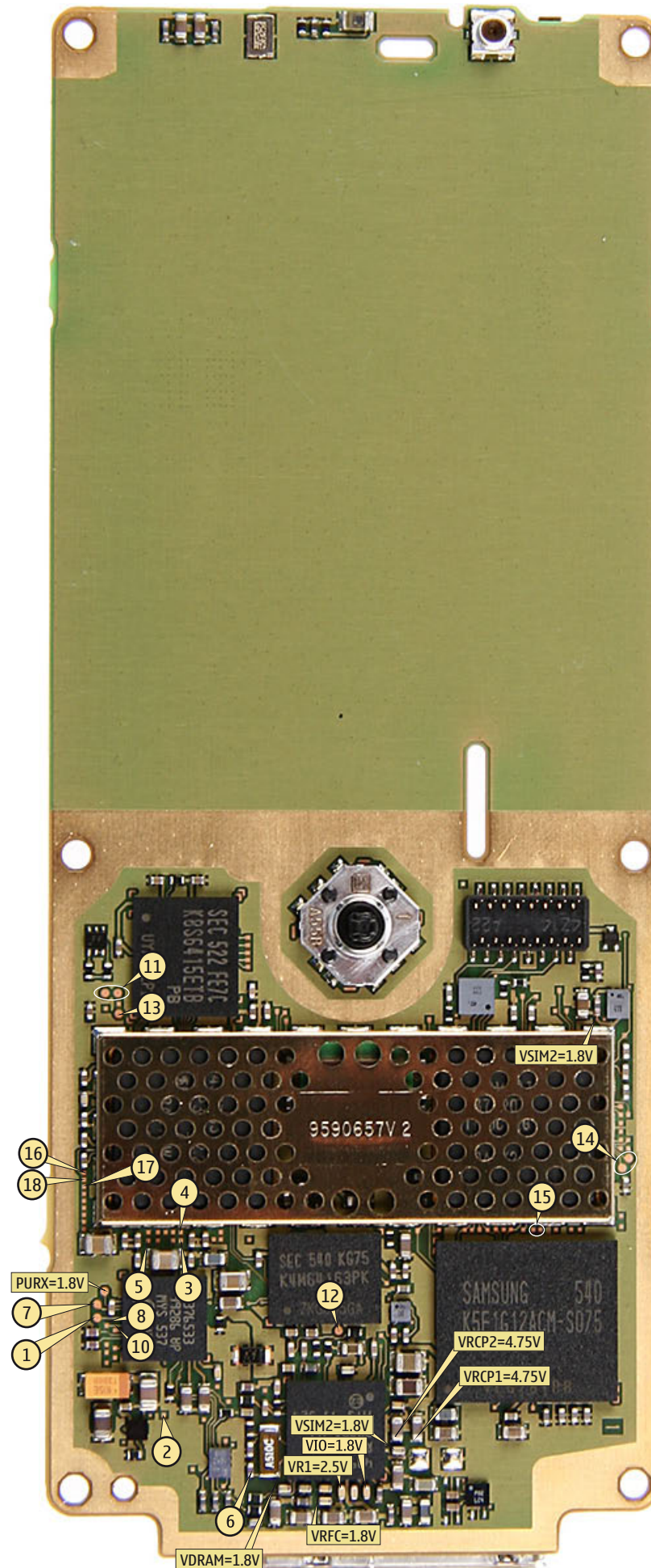
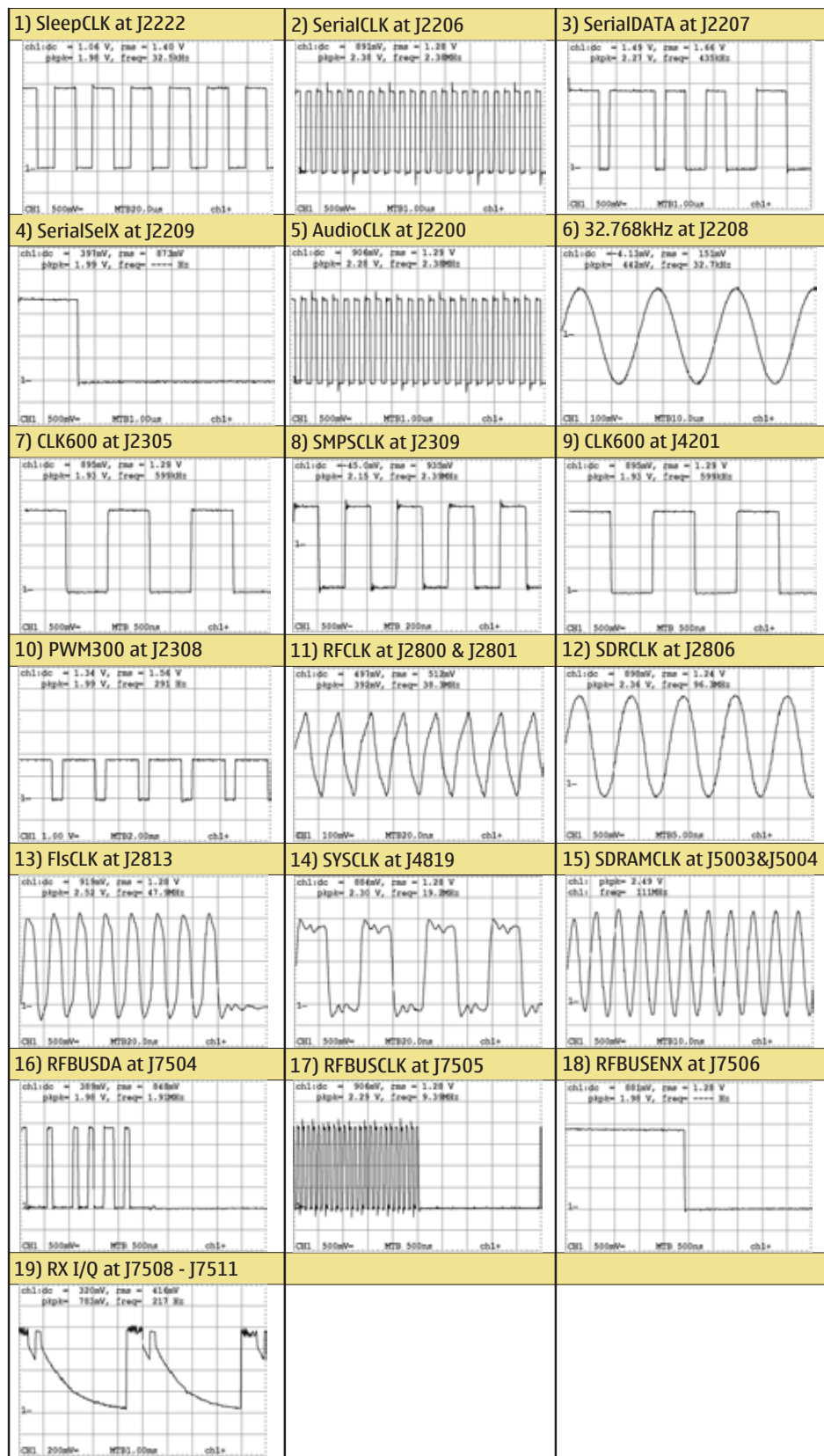

B	C2313	T3	C5202	N8	C7505	F5	D	J3103	O1	J6032	O8	L7512	H6	R5100	L8	Z2003	V3							
B2200	U4	C2314	U1	C6030	I3	C7507	E6	D2800	Q3	J3104	O2	J6033	I2	L7514	D8	R5200	O9	Z4400	O7					
C	C2315	T2	C6031	J3	C7508	E6	D3000	N2	J3105	P1	J6034	H2	L7515	F8	R5201	N9	Z4401	A3						
C2000	U4	C2316	U2	C6033	I3	C7509	D6	D3001	S4	J3106	P2	J6035	I2	L7516	G2	R5202	N8	Z4402	A2					
C2001	V4	C2700	T5	C6036	I2	C7512	D3	D4400	P5	J3107	M7	J6036	O9	L7517	H4	R6054	H2	Z4403	A3					
C2002	U6	C2800	P4	C6037	H2	C7513	F5	D4800	Q7	J3108	M7	J6303	M6	M	R6055	H2	Z6300	M3						
C2003	U5	C2801	P1	C6038	H3	C7514	D3	D5000	S7	J3109	M8	J6304	K3	M2100	K1	R6065	H1	Z6301	M6					
C2004	U5	C2802	R3	C6039	I3	C7515	G5	D6030	H2	J3110	O1	J6305	K2	N	R6300	L4	Z7500	G2						
C2005	U6	C2803	R2	C6040	I3	C7516	G6	F	J3111	M7	J6306	Q9	N2200	U5	R6301	K4	Z7501	D6						
C2006	U6	C2804	O1	C6041	H3	C7518	D4	F2000	V3	J3112	M7	J6308	J4	N2300	S2	R6354	K6	Z7502	B8					
C2007	U7	C2805	Q4	C6042	I3	C7520	D5	G	J3113	M8	J6309	J3	N2301	U2	R6370	O1	Z7503	G3						
C2008	U7	C2806	O3	C6043	I2	C7522	F6	G2200	Q1	J3114	M7	J6310	L5	N4200	L8	R6424	K3	Z7504	D3					
C2009	U6	C2807	P1	C6044	H2	C7523	C3	G6030	H3	J3115	R1	J6311	L4	N4401	S1	R6441	M5	Z7505	E9					
C2010	U7	C2808	P1	C6045	H2	C7524	G6	G7500	G5	J3116	R1	J6314	H2	N4402	Q4	R6442	N5	Z7506	H6					
C2011	V3	C2809	Q1	C6051	H3	C7525	C3	G7501	F4	J3117	R1	J6315	H2	N5200	N9	R6443	N5							
C2071	T3	C2810	R2	C6300	K2	C7526	G5	G7502	G8	J3118	R1	J7503	D5	N6030	I3	R7501	G6							
C2100	V6	C2811	Q1	C6301	K3	C7527	E6	J	J3119	P1	J7504	O1	N6031	H3	R7502	G5								
C2101	V6	C2812	R3	C6302	L3	C7528	E6	J2000	U6	J3120	O1	J7505	R1	N6300	K5	R7503	I5							
C2102	T5	C2813	R4	C6303	K3	C7529	F5	J2001	V3	J4201	L8	J7506	Q1	N6301	N5	R7504	E5							
C2103	C7	C2814	P4	C6304	L4	C7530	F5	J2002	U3	J4202	L8	J7508	O2	N6302	N5	R7505	F6							
C2104	C7	C3000	M3	C6305	L3	C7531	E6	J2003	U3	J4400	O6	J7509	O2	N6303	N4	R7506	E2							
C2105	C4	C3001	N2	C6307	L4	C7532	F5	J2060	N7	J4800	R8	J7510	O2	N6304	N3	R7509	G4							
C2106	C4	C3002	M2	C6308	K5	C7533	G4	J2070	I8	J4802	R6	J7511	O2	N7500	E5	R7512	G2							
C2109	L1	C3003	O3	C6309	K6	C7534	E4	J2071	I7	J4803	U7	J7515	R1	N7501	H5	R7514	G6							
C2110	L2	C3004	S6	C6310	L5	C7536	E5	J2072	I7	J4805	U7	J7516	O2	N7502	F3	R7516	E3							
C2114	L8	C3005	S5	C6311	K5	C7541	G5	J2200	R2	J4806	R6	J7517	Q1	N7503	D7	R7518	E4							
C2115	L8	C3006	T4	C6312	L6	C7543	H5	J2201	R2	J4807	R8	J7518	E5	N7504	F8	R7519	I4							
C2200	T5	C3007	T4	C6313	K6	C7545	F4	J2202	R2	J4808	R8	J7519	C2	R	R7520	H6								
C2201	V4	C3008	R3	C6314	L5	C7547	H4	J2202	U3	J4811	T1	J7520	E5	R2000	U5	R7521	H5							
C2202	T4	C3100	M8	C6315	K5	C7548	G4	J2203	T3	J4812	T1	J7521	F4	R2001	U5	R7522	F7							
C2203	U4	C4200	K7	C6317	L5	C7549	G6	J2204	R2	J4813	Q9	J7522	T4	R2002	U6	R7523	I4							
C2204	T4	C4201	K7	C6318	L5	C7550	I4	J2205	R2	J4814	T1	L	R2003	U6	R7525	F7								
C2205	O4	C4202	L8	C6319	K5	C7552	I5	J2206	U2	J4815	T1	L2000	U4	R2004	U7	R7526	E8							
C2206	T4	C4405	A2	C6320	K4	C7553	I5	J2207	R2	J4816	R9	L2001	U6	R2005	U7	R7527	E8							
C2207	U3	C4407	A3	C6321	L4	C7554	H7	J2208	R3	J4817	R9	L2002	U6	R2006	U7	R7528	H4							
C2208	U3	C4408	S1	C6322	K3	C7555	H7	J2209	R2	J4818	Q9	L2003	U7	R2007	U3	R7529	E8							
C2209	U3	C4409	S2	C6323	L4	C7556	F2	J2211	O4	J4819	Q9	L2100	C7	R2009	V3	R7530	E7							
C2210	V6	C4410	S1	C6324	K3	C7558	H6	J2212	O4	J4821	O7	L2101	K8	R2010	T2	R7531	E7							
C2211	T6	C4411	S1	C6325	K4	C7559	E2	J2213	O4	J4822	O7	L2102	C5	R2011	V3	R7534	E4							
C2212	U5	C4413	B7	C6326	L4	C7560	I5	J2214	V3	J4823	Q9	L2103	C5	R2070	I7	R7537	H7							
C2213	V4	C4414	R5	C6327	K3	C7561	F2	J2215	T5	J4824	P9	L2104	K8	R2071	U8	S								
C2214	V5	C4415	O5	C6328	M4	C7562	I8	J2219	S1	J4825	Q9	L2105	M2	R2100	V7	S4429	N5							
C2215	V5	C4416	Q5	C6329	M4	C7563	E2	J2220	T3	J4826	Q9	L2106	M2	R2101	T4	S4436	A8							
C2216	V5	C4418	R4	C6330	M4	C7564	E3	J2221	R3	J4827	P9	L2202	V6	R2104	B7	S4437	H1							
C2217	V4	C4419	P4	C6331	N6	C7567	H6	J2222	S1	J4828	P9	L2203	V5	R2105	C7	S4438	D1							
C2219	V4	C4420	R4	C6332	N6	C7568	I4	J2300	U3	J4829	O8	L2204	V4	R2106	C4	S4439	F1							
C2220	U5	C4421	O6	C6333	M5	C7569	E2	J2301	T1	J4830	Q9	L2205	U6	R2200	T5	T								
C2221	U5	C4422	Q6	C6334	M5	C7570	I5	J2302	R2	J5001	R7	L2206	V5	R2201	T3	T6030	J3							
C2222	U6	C4423	N8	C6335	N6	C7571	H9	J2305	S1	J5002	R7	L2301	R3	R2202	U3	T6300	L6							
C2223	T5	C4800	P6	C6336	N4	C7572	G2	J2308	S1	J5003	R8	L2302	R1	R2205	U3	T7500	D6							
C2224	T4	C4801	R6	C6337	N4	C7573	I4	J2309	S1	J5004	R7	L2304	U1	R2304	U2	T7501	F6							
C2225	U6	C4802	Q6	C6338	N5	C7575	I6	J2800	O1	J5005	R6	L4200	L7	R2305	N1	T7502	G3							
C2226	V6	C4803	Q6	C6339	N4	C7577	I6	J2801	O1	J5006	R7	L4201	K8	R2306	N1	T7503	G7							
C2227	V4	C4804	P9	C6340	N3	C7579	D7	J2803	R2	J5007	R7	L4401	A2	R2307	S3	V								
C2228	V5	C4805	P6	C6341	N4	C7580	D8	J2804	R3	J5008	R7	L4403	A3	R2700	S6	V2000	U4							
C2230	V4	C4806	P6	C6342	M3	C7581	D3	J2805	S5	J5009	R7	L4404	Q4	R3000	M2	V2300	N1							
C2231	T6	C4807	O7	C6343	N3	C7582	I5	J2806	S5	J5010	R7	L4405	T4	R4414	U4	V2301	T3							
C2232	V5	C4808	O7	C6344	L6	C7583	F7	J2807	R3	J5100	K9	L5200	O8	R4415	A4	V4401	N9							
C2233	P2	C4809	Q6	C6345	K6	C7584	D3	J2808	Q4	J5101	L9	L6030	J2	R4416	A4	V4410	A5							
C2235	S1	C4810	P9	C6346	K4	C7585	E8	J2809	Q4	J5102	K9	L6031	I3	R4417	A4	V7500	E8							
C2236	V5	C4811	Q9	C6347	K4	C7586	E9	J2810	Q4	J5103	K9	L6301	M5	R4423	T2	X								
C2300	R3	C4812	R6	C6348	K5	C7587	E9	J2811	Q4	J5104	M8	L6302	N6	R4427	B7	X2001	V6							
C2301	R2	C4813	P9	C6351	K3	C7589	F8	J2812	N3	J5105	L9	L6303	M4	R4432	O7	X2060	A3							
C2302	R1	C5000	U7	C6352	K6	C7590	E8	J2813	O2	J5106	N8	L6304	M5	R4433	O7	X2070	I7							
C2303	T2	C5001	U8	C6360	L6	C7591	E7	J2814	N3	J5107	N8	L6305	N5	R4434	T4	X2700	R4							
C2304	R2	C5002	T6	C6361	K6	C7592	E7	J2815	N3	J5108	K9	L7502	I5	R4451	O6	X4400	N7							
C2305	T1	C5003	U8	C6364	M3	C7593	F2	J2816	N3	J5109	K9	L7503	G4	R4454	Q6	X4401	B3							
C2307	S3	C5004	U8	C6365	M3	C7594	E2	J2817	N3	J5110	K9	L7504	D3	R4455	N8	X5003	A7							
C2308	T1	C5005	S6	C6410	L3	C7596	D5	J2818	O2	J5111	L9	L7505	D3	R4800	O6	X5200	Q7							
C2309	S3	C5006	U7	C7501	D5	C7597	I9	J3100	O2	J5112	J2	L7506	C3	R4801	K8	Z								
C2310	S1	C5200	O8	C7503	E4	C7598	G5	J3101	O1	J6030	O7	L7510	H6	R4802	K8	Z2000	V3							
C2312	T3	C5201	N9	C7504	E5	C7599	H7	J3102	O1	J6031	O8	L7511	H6	R4809	R5	Z2001	V3							

